

SIEMENS

Positioning and Path Control Module FM 357-2

Product Brief

November 2001

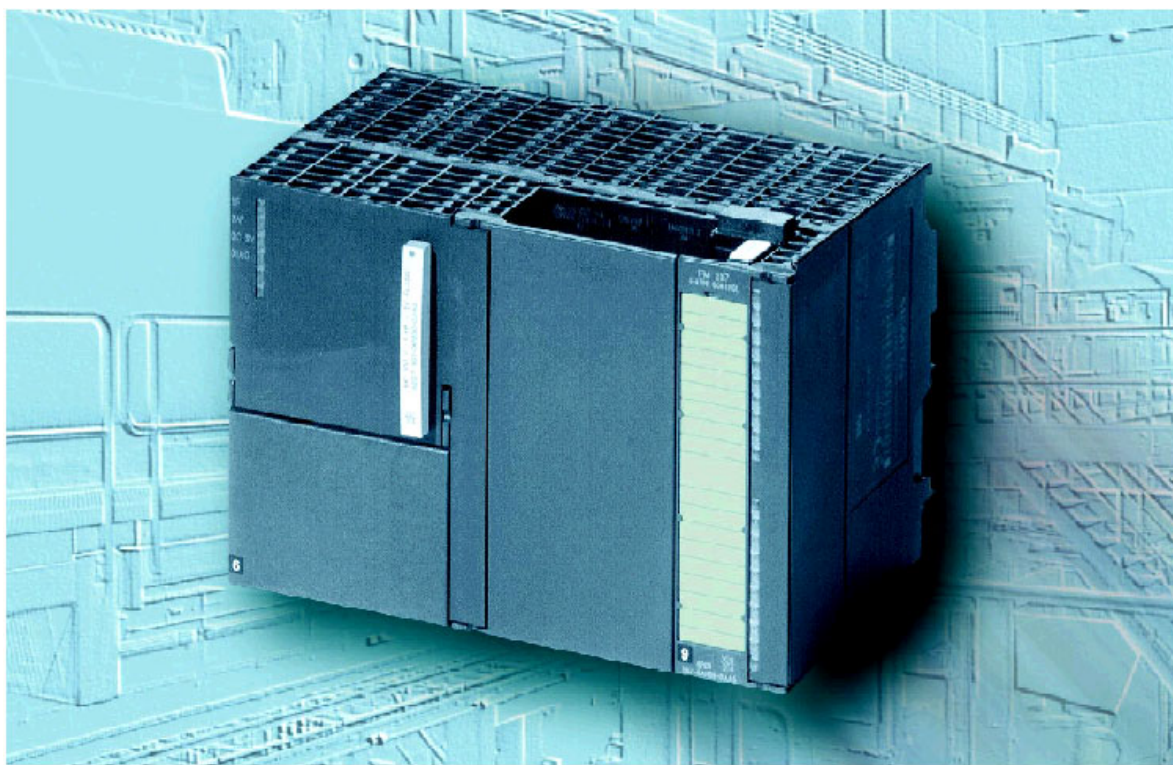

Copyright Siemens AG 1997-2001 All rights reserved

The reproduction, transmission or use of this document or its contents is not permitted without express written authority. Offenders will be liable for damages. All rights, including rights created by patent grant or registration of a utility model, are reserved.

Siemens AG
Automation and Drives
Motion Control Systems Division
P.O. Box 3180, D- 91050 Erlangen

Siemens Aktiengesellschaft

Exclusion of liability

We have checked that the contents of this publication agree with the hardware and software described herein. Nonetheless, differences might exist and therefore we cannot guarantee that they are completely identical. The information given in this publication is reviewed at regular intervals and any corrections that might be necessary are made in the subsequent printings. Suggestions for improvement are welcome at all times.

© Siemens AG 1997-2001
Subject to change without prior notice.

Multi-Axis Module FM 357-2

Positioning and Path Control Module FM 357-2

Contents

CONTENTS.....	3
APPLICATIONS.....	4
<i>General</i>	4
<i>Areas of usage</i>	4
DESIGN.....	5
<i>Hardware components</i>	5
<i>Software components</i>	5
<i>Hardware design</i>	6
<i>The S7-300 CPU</i>	7
<i>Programming device with parameterization tool</i>	8
<i>Operator control and monitoring with Operator Panels</i>	9
<i>PC link</i>	10
DRIVE TECHNOLOGY.....	11
<i>Positioning</i>	11
<i>Suitable drive systems</i>	12
APPLICATION OF THE FM 357-2.....	13
<i>Preparatory steps</i>	13
<i>Creation of motion programs</i>	14
<i>Program execution</i>	15
<i>Functions</i>	16
<i>Technology blocks</i>	17
<i>Performance</i>	17
<i>Data Storage</i>	18
START-UP	19
<i>General</i>	19
<i>Operating modes</i>	19
<i>Monitoring functions</i>	20
TECHNICAL DATA	21

Applications

General

The FM 357-2 is a path and positioning control module for intelligent motion control of up to four axes. It allows a comprehensive range of applications from independent single positioning axes to interpolatory multi-axis path control.

The programming language for motion control in accordance with DIN 66025 is also widely used in mechanical engineering. It enables programming of simple "to and from" movements as well as complex 3D curve movements with just a few, powerful commands.



The positioning module excels in particular where flexible motion control is required. With its close communication with the PLC system and its integrated independent real-time operating system, motion sequences can be programmed according to any conceivable kind of external factor.

Areas of usage

The module is particularly suitable for the following application fields:

- For the metal, wood, plastics and stone processing
 - Milling, shaping
 - Engraving
 - Cutting, deburring
 - Bending, canting
- In the textile and packaging industry
 - Sewing, embroidering
 - Inserting
 - Cutting to size
 - Erecting, folding
 - Palletizing, stacking
- For winding machines
 - For electronic and electro-mechanical components
 - For ropes and wires
- In handling applications
 - Pick and place
 - Loading machines
 - Storage and retrieval machines

The FM 357-2 is capable of controlling both stepper drives and position-controlled servo drive axes. Installation and start-up is facilitated by a user-friendly tool which is integrated into STEP7. The parameterization wizard guides inexperienced users without the knowledge of "machine data" through to successful installation and start-up.

Three firmware versions – FM 357-2 L, FM 357-2 LX and FM 357-2 Handling – are available to adapt the module's functionality to the individual application field, thus offering an optimum price/performance ratio.

The mechanical design of the module as well as the communication structure contribute to a perfect integration into the SIMATIC S7-300 system.

Design

Hardware components

Item	Components	Remarks
S7-300 PLC-System	S7-CPU	PLC CPU
	I/O components (optional)	Input/output modules, communications processors FM modules
FM 357-2 hardware	S7-300 module	Hardware module without firmware
Drive technology	SIMODRIVE 611 A (analog) or 611 U (analog or via PROFIBUS-DP) POSMO C and POSMO SI (via PROFIBUS-DP) MASTERDRIVES MC (analog) / servo converter or FM STEPDRIVE stepper drive power module	Power converter for position-controlled servo drives or stepper motors
	AC servo motors SIMOSTEP stepper motors	Motors for axis drive
Operator component (optional, for FM 357-2 H only)	Hardware Handheld programming unit MPI type or Handheld terminal HT 6	SIMATIC HMI operator panels for machine-level operator control and monitoring Particularly recommended: OP 17 Teach-in for FM 357-2 H only

Software components

FM 357-2 firmware on coded memory card	System firmware on memory card	Memory card for installing the firmware on to the module and for storing user data
FM 357-2 configuration package (identical for L, LX and Handling)	Documentation	Electronic documentation; paperback manual can be ordered separately
	Parameterization tool "FM Param"	Configuration software; installed into and called from STEP7
	S7 technology blocks	"Basic program" for S7 consisting of FCs, FBs and DBs for data transfer and communication
	NC-VAR selector	Auxiliary program for selection and integration of FM-357-2 (NC-) variables in the S7-CPU
	Sample screen forms for OP 27 and OP 17	Premade screen forms with standard displays for demonstration of the integration via data server or native protocols
SIMATIC STEP 7	Floppy disks or CD with authorization disk	Programming environment for SIMATIC S7 PLCs ≥ Version 4.02, recommended V5
SIMATIC HMI PROTOOL/PRO (optional)	Floppy disks or CD	Configuration tool for configuring SIMATIC HMI components ≥ Version 2.51, recommended V3
"Edit-FM" program editor	Floppy disk	Stand-alone program editor for editing and management of motion programs on any PC with MPI interface

Hardware design

The FM 357-2 is inserted in a **S7-300 system rack** and requires at least an S7-CPU. The FM has 12 digital inputs and 8 digital outputs onboard which can be used freely within the program. If required, these internal I/Os can be expanded by optional I/O modules (digital and/or analog).

In addition to the FM 357-2, further independent FM modules (such as counter modules or additional positioning modules as auxiliary axes) can be inserted in the same rack. Up to three FM 357-2 modules (but only one FM 357-2 Handling) can be inserted in one rack.

To the right of the FM 357-2 **digital and/or analog I/O modules can be used as local I/O** (max. 2 modules). These modules can then be addressed directly as fast I/Os in the motion program in addition to the digital onboard I/O (e.g. with the integrated CAMs or as path-velocity dependent analog output).

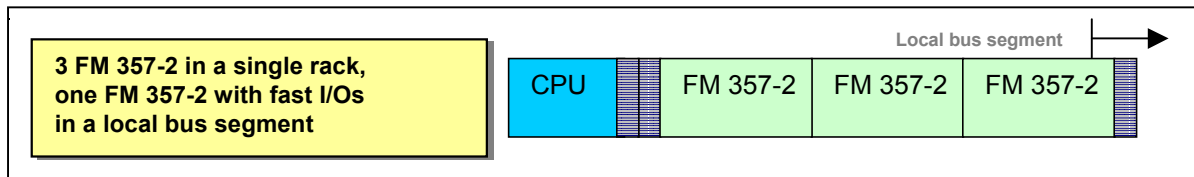

If there is more than one FM 357-2 with local I/O to be used with one CPU, the second or third FM 357-2 needs to be placed in a separate expansion rack using the interface modules IM360/361.

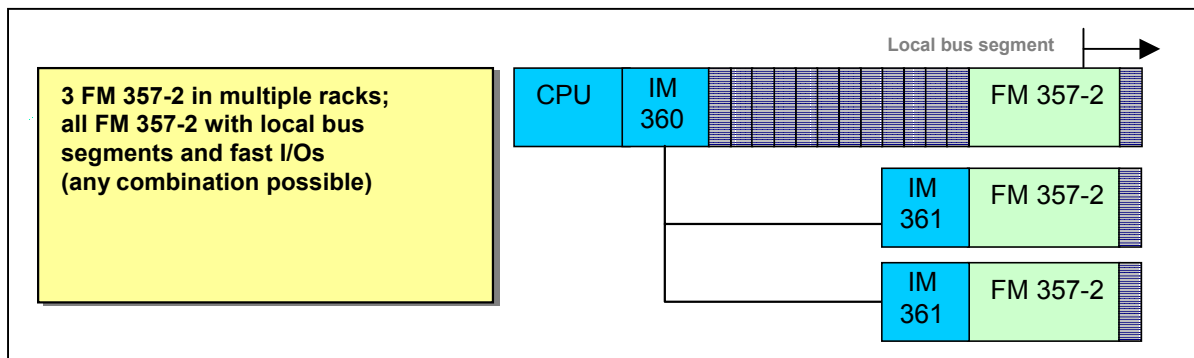

Up to 3 FM 357-2 can also be placed in ET 200M racks as distributed I/O and therefore can also be integrated into an S7-400-System. With such decentralized configuration the performance of a central installation will however not be reached.

With distributed operation it is not possible to implement a local bus segment, therefore no additional high-speed inputs/outputs can be connected to the FM 357-2.

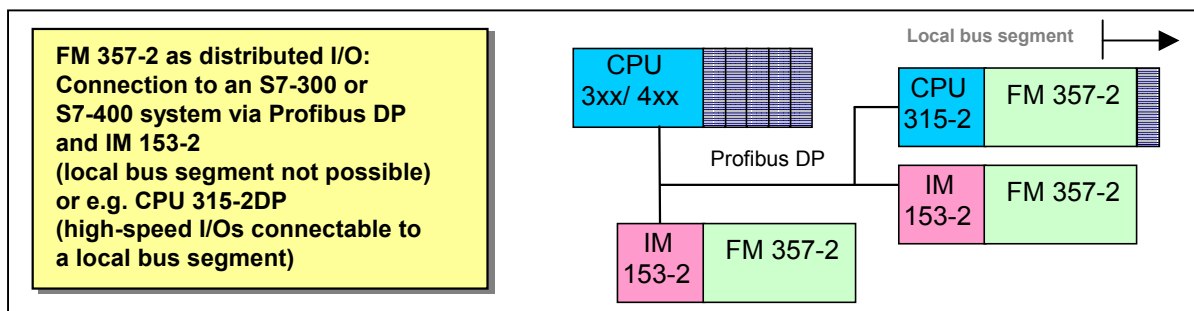

For applications in distributed configurations (via Profibus-DP) the FM 357-2 can also be operated using a rack with a separate CPU (CPU 315-2DP) in line with the concept of "distributed intelligence". All components required for motion control are installed in one place, which keeps data transfer to a minimum and provides a modular software structure.

The S7-300 CPU

The **S7-300 CPU** is the core part of the system. **At least a CPU 315** (or CPU 314 IFM) is required for motion control with the FM 357-2, as approximately 10 KB CPU-memory are needed for the minimum communication with the FM 357-2. For larger configurations we recommend a CPU 316 or CPU 318. Alternatively, a C7-626 system or a C7-3xx can be used instead of the S7-CPU.

In most applications the motion program runs independently on the FM module whereby data and status messages are cyclically exchanged with the CPU. From the motion program of the FM 357-2 "M commands" can be used to trigger actions in the S7-CPU and data can be read and/or written.

The S7-CPU can read out and influence the most important operating parameters of the FM 357-2, providing full control of the traversing movements from the CPU. In this manner, "traversing blocks" can even be written directly into the FM 357-2, for example, to obtain completely independent motion sequences. However, this memory-intensive operating mode, called "PLC positioning axis", is only recommended for simple motion sequences or in exceptional cases.

The powerful transfer of parameters is particularly suited for flexible motion programs. Thus the motion program in the FM 357-2 is controlled via external parameters, for example allowing "scaling" of contour movements from outside the FM without changes being made to the program.

The entire motion control program is generally programmed in the large user memory provided on the FM 357-2 (approx. 770 KB), which offloads the S7-CPU.

The following are some of the functions frequently used within the communication between FM and S7-CPU:

- Start/stop traversing movements
 - Starting and stopping selected motion programs
 - Direct triggering of independent positioning movements
- Specification of target positions
 - Via transfer of parameters
 - Via direct writing of values
- Selection of motion programs
- Setting and reading out operating modes
- Transfer/acceptance of parameters
 - For setting parameters for motion programs
 - For output and further processing of operating parameters

Programming device with parameterization tool

A programming device or PC with MPI interface is required for start-up and maintenance. The STEP 7 basic system forms the core component and is used in the usual way to create the PLC user program.

The FM's configuration package includes a parameterization tool for parameterizing and programming the FM 357-2. It is integrated into STEP 7 and can be called directly from the STEP 7 Hardware configuration.

The FM 357-2 parameterization tool builds on the look and feel of the S7-FM module range and Microsoft Windows. The tool can be used online on the premises or offline in the planning office. A configuration that was created and stored on the PG/PC can be loaded into the module later.

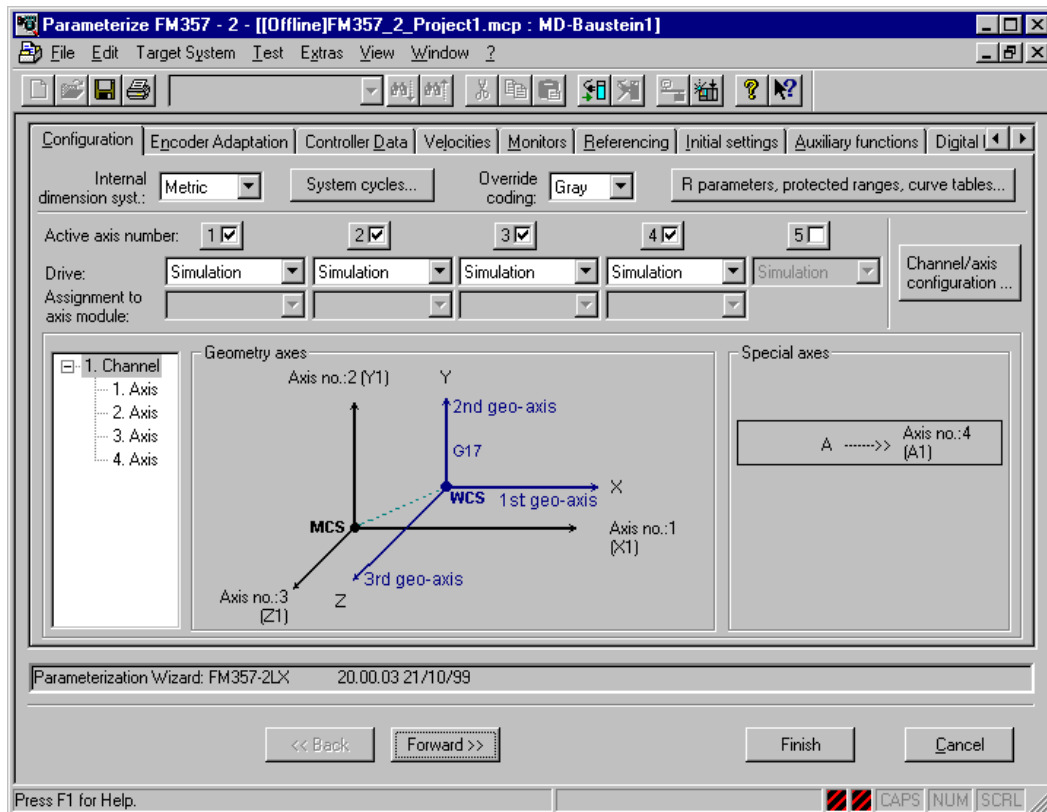

(Parameterization tool - Parameterization wizard)

Various tools are integrated into the parameterization software such as:

- **Parameterization wizard**
A guided start-up routine allowing fast parameterization of the module – no need to input cryptic machine data lists. All input data is preset with realistic empirical values and a technology-oriented online help function completes the system for entry-level users.
- **List-oriented expert mode**
A mode where all parameters and machine data are displayed and processed in a list. Here the experienced user is given the possibility to activate rarely used, system-critical functions.
- **Program editor**
A Windows ASCII editor is used for creating motion programs or importing and exporting existing program code. The standards implemented support the use of third-party DIN code or customized applications (such as export filters from CAD systems).

- **Testing and operator control screen form**

This tool permits offline operation in real-time mode. It allows the user to traverse single axes, test programs and set operating modes. In addition, all main operating parameters are displayed online. Error messages are displayed and saved online with context-oriented acknowledgement.

- **Trace function**

An integrated "storage oscilloscope" for recording positioning operations. If required, this can be used to achieve optimum adaptation of the controller parameters to the mechanics and drive train as well as for extended diagnostics.

Operator control and monitoring with Operator Panels

There are two possible ways to connect HMI components:

- **the indirect connection via the S7-CPU**

As all the important operating parameters of the FM 357-2 can be represented in the S7-CPU (for example in data blocks), they are available in the entire automation system for visualization and operating purposes. Therefore, all components can be used - ranging from a simple text display right up to the visualization system WIN CC. However, due to the communication method there will be a load on the S7-CPU.

- **the direct connection via native protocol or data server**

The OP7 and OP17 operator panels support direct communication with the FM 357-2 using a "native protocol driver". By this means, virtually all relevant operating parameters can be displayed and manipulated without loading the CPU, resulting in faster communication rates.

The following functions are supported:

- Stop/start program, control program
- Read, display and write variables directly
- Program list with selection dialog
- Output alarms in plain text
- Indirect axis selection via parameters (expanded multiplexing)
- > 125 R-parameters can be processed.

The functions can be configured directly and easily using PROTOOL V3.x or higher.

The FM 357-2 features an integrated data server for operator panels OP27 and greater, allowing them to communicate directly with the FM 357-2. However, this option has a few restrictions (no program selection via lists, max. of 125 parameters, no direct configuration).

Basically, the SIMATIC HMI components can be used to set parameters for all motion programs, but it is not possible to edit the programs directly from the HMI. For editing and creating motion programs the parameterization tool is required.

PC link

An FM/NC channel DLL is available (on request) providing all important functions for WIN CC users.

The Edit-FM tool is available for linking additional PC applications.

It provides a program editor (like in the parameterization tool) and services for saving and loading NC programs on the PC or into the FM. The use of Edit-FM does not require STEP7 to be installed on the PC.

It can be used for the function modules FM 353/354/357-2 and FM453. For the communication with the controller an MPI or Profibus interface is needed in the PG/PC.

Edit-FM can also be remotely operated as an OLE server via external applications. This requires the "Windows Scripting Host" services (supplied, included in Windows 98). The application can also be remotely operated via customer applications (e.g. VBA) .

The following functions are available with Edit-FM:

- Connection setup with the FM
- Loading and saving/deleting programs on the FM
- Loading and saving/deleting programs on the PC

The control of the production process (e.g. starting/stopping programs) is not possible with Edit-FM. However, it is possible to use the separate driver software "PRODAVE MPI" to establish communication with the S7-CPU, from which the FM can be controlled.

Drive technology

Positioning

Different tasks require different types of drive technology:

- **Simple, slow positioning** (several seconds to minutes) where the target points are always fixed is directly controlled by means of the S7-CPU via limit switches and standard induction motors with pulse converters.
- Simple and **slow positioning** (several seconds to minutes) **with variable target points** is implemented with encoders via rapid traverse/creep feed positioning (for example, with the FM 351). Generally, induction motors with pulse converters are used for cost reasons (e.g. SIEMENS Micromaster).
- **High-speed positioning** (seconds to less than 10 ms) with single axes that also require flexibility and precision during the motion process (cm to sub-mm range) is implemented by means of stepper motor systems with FM 353, FM STEPDRIVE and SIMOSTEP, or position-controlled systems with FM 354 and SIMODRIVE 611 A/U or SIMOVERT MASTERDRIVES MC servo drives. With three or four axes, the FM 357-2 module may be the most economical solution, too.
- **High-speed positioning tasks** requiring close coordination of axes up to **interpolation and path control**, are implemented with an FM 357-2.

The FM 357-2 masters both operation of controlled or position-controlled stepper drives as well as position-controlled servo drives. It is also possible to use high-performance frequency converters with "vector control". The FM 357-2 does not support operation of controlled three-phase converters or comparable systems.

The connection of drives via PROFIBUS-DP (clock-cycle synchronous, equidistant) is possible, however, only the SIMODRIVE 611U and POSMO C or SI are supported (not with Firmware Version H combined with a Handheld programming unit PHG or Handheld terminal HT 6). Parallel operation of a PG/PC for configuration of the drives via PROFIBUS is not possible on the FM's PROFIBUS-DP interface at the moment.

The encoders can be either RS 422 (TTL) incremental encoders or SSI absolute encoders. The encoders can be used at any location in the installation – linear scales via emulations (with SIMODRIVE 611U) are also possible. Please note that the contact with the moving element must be form-fitted.

Suitable drive systems

Type	Application	Reference point	Rotation monitoring	Remark
Stepper motor without encoder FM STEPDRIVE, SIMOSTEP	High-speed positioning of smaller masses, positioning drives	Required	Cyclical signal (e.g. BERO) on high-speed FM 357-2 input)	SIMOSTEP is shock-load tolerant
Stepper motor with incremental encoder	Fault-tolerance high-speed positioning of smaller masses, positioning drives	Required	Via position controller of FM 357-2	Fully position-controlled operation, compact design of power converters as alternative to servo drives
Stepper motor with absolute encoder	Positioning drives and high-speed positioning of smaller masses with high safety requirements	Not required	Via position controller of FM 357-2	Fully position-controlled operation, compact design of power converters as alternative to servo drives
Servo drives with incremental encoder MASTERDRIVES MC; SIMODRIVE 611A/U POSMO C and SI	Fast motion of larger masses, highest dynamics for handling systems	Required	Via position controller of FM 357-2, speed controller monitoring in the power converter	Rotary and linear drives
Servo drives with absolute encoder SIMODRIVE 611A/U POSMO C and SI	Fast motion of larger masses, highest dynamics for handling systems, gantries. Demands high availability of installation.	Not required	Via position controller of FM 357-2, speed controller monitoring in the power converter	
Frequency converter with vector control MASTERDRIVE VC/MC	Slow positioning of larger masses.	(Acc. to the measuring system – see servo drive)	(Acc. to the measuring system – see servo drive)	Necessary to modify standard values for position controller. Can only be operated with high-performance control – on request.
Hydraulics with linearized servo valve or "NC amplifier" (on request)	Slow positioning of larger masses, restricted dynamics (type servo gain < 1)	(Acc. to the measuring system – see servo drive)	Via position controller of FM 357-2	High-quality servo valve or "NC amplifier" (e.g.: Rexroth SVNC) required. Pressure controller possible.

The above mentioned drive systems can be used on the FM 357-2 in hybrid operation.

Application of the FM 357-2

Preparatory steps

Analysis of mechanical and process conditions:

The FM 357-2 L and LX can be configured for rotary and linear axes in the Cartesian coordinate system.

In addition to the above functions, the FM 357-2 H performs motions such as SCARA and articulated-arm kinematics for handling and robotics applications. Special kinematics (eccentric, pantograph, delta) can be linearized by the program via integrated real-time arithmetics with all firmware types. Here, however, the necessary computation time must be taken into account.

The following distinctions must be made:

- Positioning:** A motion axis is traversed one-dimensionally from the start to the end point. The behavior between the start and end point is generally only specified by a speed limit ("to and from motion").
Examples: conveyor systems, hoisting devices and positioning drives
- Synchronization:** The motion of additional axes depends on another axis or an external master value. Here variable conditions can be specified, for example, in tables. One axis is the master, the others follow as slaves.
Examples: conveyor systems, tubular bag machines
- Interpolation:** The path between start and end position is calculated at a higher level based on different mathematical functions and motion of all axes is controlled accordingly. The resulting path of a tool therefore consists of a number of superimposed single movements. Additional specifications such as velocity profiles and path optimizations are also possible.
Examples: metal, wood and plastics processing, robotics, handling systems

The FM 357-2 supports operation of an interpolation or synchronization group with a maximum of 4 axes for one motion sum. Any remaining axes (e.g. 3 + 1) can be used as independent positioning axes.

An external master value (e.g. an encoder on a shaft) can be connected via a measuring circuit, so that 3 axes are still available for motion control.

The FM 357-2 supports up to 4 program channels for internal motion programs (FM 357-2 Handling: 1 channel) to which the 4 axes can be assigned in any combination (e.g. 2+2 axes, 3+1 axis, 4*1 axis). Each axis channel operates as an "independent" module whereby the on-board I/Os can be addressed by all channels equally. Additional FMs can be inserted into the S7-300 rack and controlled via the S7-CPU for additional positioning tasks.

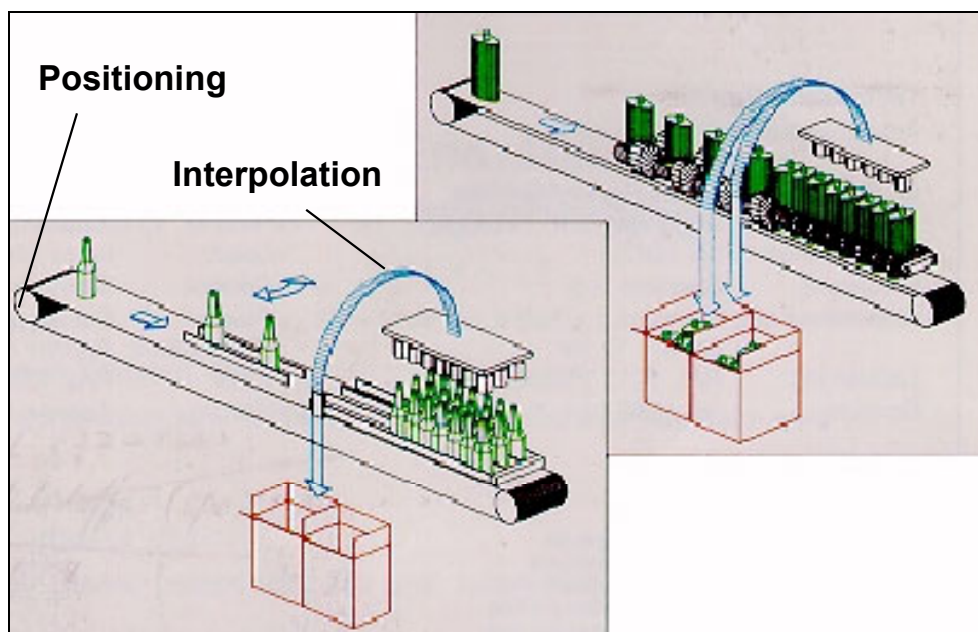

(Application example - Handling system with positioning axis as conveyor drive)

Creation of motion programs

In general, motion sequences are controlled as follows:

1. as **interpolating axis group** in the motion program on the FM 357-2
2. as **independent NC positioning axes** (single axes) in the motion program on the FM 357-2
3. as **"PLC positioning axes"** by direct writing of motion commands into the NC memory

The motion program in the FM 357-2 is created in accordance with DIN 66025. This standard is widely used in mechanical engineering to program motion sequences for metal processing. High-level language elements (conditions, loops) and floating-point arithmetic are also supported.

The example below shows a typical command syntax of a motion program:

```
N10 G90 F1000 X10 Y20
```

N10 Block No. 10 (a block is a command line that is executed at the same time)
G90 G command "absolute dimensions" (supplementary conditions are defined here)
F1000 Velocity 1000 mm/min (dimensions can be configured)
X10 Y20 End point of the movement: X/Y-coordinate

The FM 357-2 program memory has a capacity of approx. 770 KB and is fully available for motion programming. The parameterization tool provides a program editor for editing and creating programs. The editor features syntax coloring and a context-sensitive help function.

```
Parameterize FM357 - 2 - [[Offline]FM357_2_Project1.mcp : PROG1E.MPF]
File Edit Target System Test Extras View Window ?
N110 G64 ADIS=10
N130 R1=0.01 R2=0.01 R3=50 ; Initialisation of variables
N140 F10000
N150 LOOP1:
N160 Y=R1 X=R2 ; Move to calculated position
N170 YO XO
N180 R1=R1+R1 ; Increment - extend position by one step
N190 R2=R2+R2
N200 IF R2<R3 GOTOB LOOP1 ; Call infinite loop
N300 ASPLINE ; Beginnig of spline table
N310 STARTP:
N320 F10000
N330 X300 Y200
N340 X300 Y45
N350 X10 Y56
N360 X20 Y100
N370 XO YO
N380 X300 Y45
N390 X20 Y10
N400 XO Y100
N410 GOTOB STARTP
N500 M2
Line: 25 Column: 0
Press F1 for Help. CAPS NUM SCRL
```

(Program editor - example program)

Program execution

The motion programs are sequentially executed. A program command ("program block") is only executed when the preceding one has been completed. **Several blocks are interpreted simultaneously** and analyzed (block pre-processing) in order to achieve continuous motion, i.e. the **next movement is prepared before completion of the preceding movement**. Therefore, it is not possible to change the motion blocks on-the-fly, that is, during motion – even if the block has not yet been executed. About 20 blocks are pre-processed in advance.

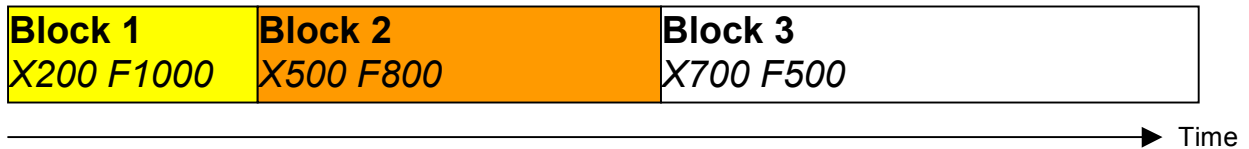

If conditions are inserted, they are examined during program execution. However, please note that the RLO is determined at the **beginning of pre-processing**, i.e. often several blocks in advance. This is necessary to ensure that the gated position is also approached in continuous traversal.

If an updated (real-time) condition is to be examined, the block buffer must be cleared by the program ("STOPRE" command). The axis then stops and continues the movement after a short time according to the new conditions.

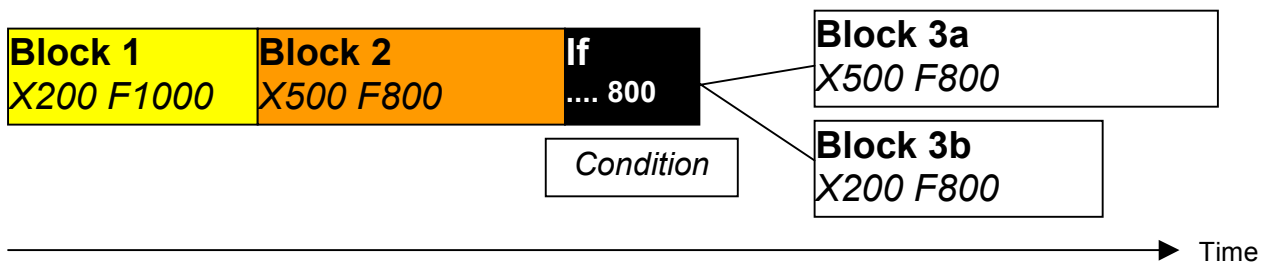

If conditions are to be permanently examined in real-time operation and a response instigated, it is necessary to set synchronous actions.

Synchronous actions are set via program commands ("Whenever" for cyclical processing, "When" for once-only processing) and are then always executed if the conditions are fulfilled. In this manner variables can be influenced or axes moved ("command axes") in real-time. However, block pre-processing must be taken into account again for the application, i.e. even with immediate execution, not all parameters are instantly effective (see manual). Parameters that are immediately effective include velocity override, offset values or setting high-speed outputs.

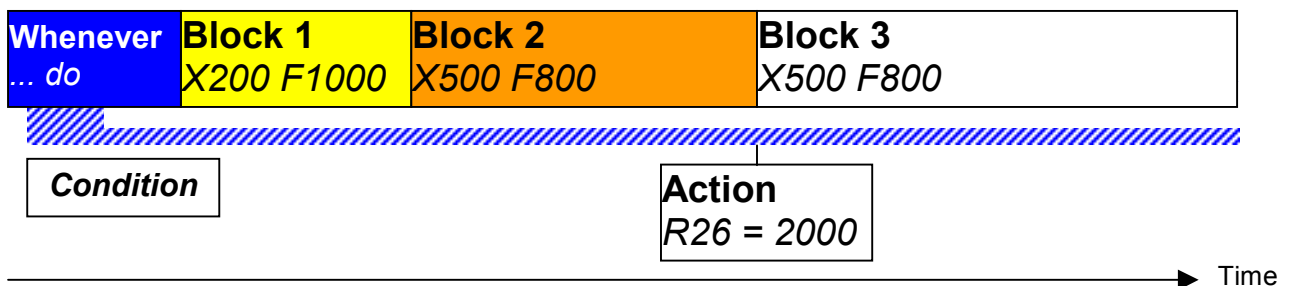

Asynchronous subprograms (ASUB) can be used to interrupt a running program in order to execute a "subroutine". The ASUB can be triggered by an external event (digital input) or a condition in the PLC.

Functions

The program can be freely structured providing the syntax and programming rules are adhered to, and it supports virtually all aspects of dynamic motion control. There are three function packages L, LX and H available.

The version LX includes the functions of the export version L plus further complex functions. The version H extends the LX version by adding some handling functions.

Positioning and path control:

- L Linear positioning of dependent/independent single axes
- L Linear interpolation of up to 4 axes
- L Circle and partly-circular (e.g. helical) interpolation
- L Interpolation by means of interpolation tables of any size
- L Programming of coupled-axis grouping (synchronized axes) of a max. of 1x3 or 2x2 axes
- L Application of internal and external master values
- LX Spline interpolation (linking interpolation points with curves)
- LX Powerful portal function with rigid compensatory control ("gantry")
- LX Superimposed oscillation motions, e.g. for spray-painting or grinding
- LX Tangential control

Traversal

- L Exact stop, transition rounding, look-ahead function for concatenated motions
- L Acceleration behavior adaptable to technological characteristics (e.g. jerk reduction, stepper drives)
- L Rapid stop or emergency retraction programmable for collision detection ("ASUB")
- L Fast resumption of the travel path after emergency stop with smooth acceleration
- L Controlled mode for drives that are difficult or impossible to control
- LX Travel to fixed stop (torque output for pressure exertion motions)

Positional data

- L Cartesian coordinate system
- L Polar coordinates
- L Angle of rotation
- L Manipulatable coordinate system (zero offset, rotation, mirroring)
- L Programming of up to 4 Cartesian protection zones
- H Coordinate transformation for SCARA and articulated-arm systems with up to 4 axes

Arithmetic

- L Full floating-comma arithmetic with basic arithmetic types and higher mathematical functions
- L Up to 100 arithmetic parameters available (can be expanded to > 1,000)
- L System variables (measurement values, actual values) can be read out and written to
- L Program-controlled transfer of variables or actions to the S7-CPU (H or M functions)

Program control

- L Program jumps, conditional and unconditional; Control structures (CASE, WHILE, ...)
- L Conditions ("IF ... then")
- L Subroutine technique; event-triggered calls ("ASUB") or execution-oriented
- L Simple interrupt routines (synchronous actions)
- LX Expanded interrupt routines with linked commands and direct axis programming
- H Teach-in operation with handheld programming unit or handheld terminal

Additional functions

- L Limit switching signals (software cams)
- L Addressing of digital and analog outputs as local I/Os
- L Output of control commands (M and H functions) to S7-CPU
- LX Fast measurement via delay-free probe assessment on 2 inputs
- LX Path velocity-dependent variable control (e.g. analog output)

Technology blocks

The coordination of the motion programs, starting and stopping of positioning processes as well as parameter transfers are conducted by the STEP7 program. The configuration package contains standard technology blocks for easy integration of the required functions into the user program.

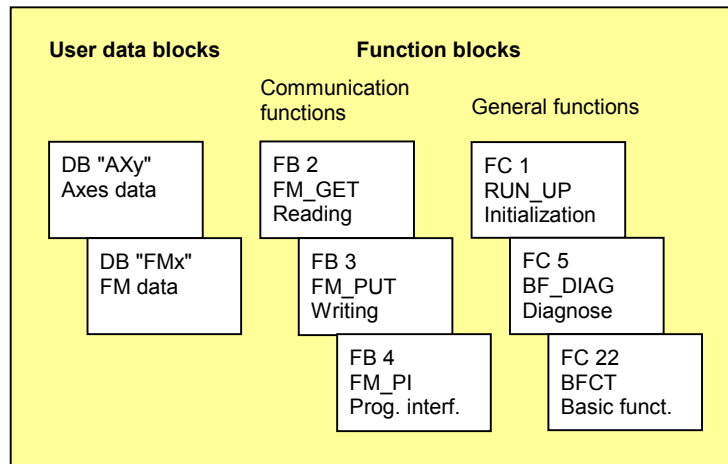

The technology blocks provide general functions and services for the communication between CPU and FM. The functions for initialization and diagnostics are executed during startup or in case of an error. The basic functions and the often required communication functions have to be integrated into the cyclical program of the CPU.

When parameterizing the FBs, motion sequences can be directly triggered by the S7-CPU without programming the FM 357-2.

The following can be specified:

- the axis number of the axis to be traversed
- the end position in inch or mm (linear axis) or degrees (rotary axis)
- the traversing path (absolute or incremental)
- the feedrate

The positioning status is reported to the CPU via checkback signals and error messages.

Performance

The programs are executed sequentially in "Automatic" mode (comparable to "RUN" for S7-CPU). The sample rate is 9 ms independent of the program and can be optimized to approx. 6 ms according to the process if required.

The following times must be taken into account for assessing the expected performance:

1. The servo cycle (2 ms) corresponds to the sampling interval of the position controller
2. Coordination of the axes (interpolation) is calculated in the IPO cycle (6 ms)
3. Cycle time of the S7-CPU
4. Communication times between the FM and the S7-CPU

The following table shows the worst case times:

Procedure	min.	typical	Remark
Response to positional deviations	2 ms	3 ms	Servo cycle
Processing the next block	6 ms	(End of traversing movement)	Dependent on the programming
Software cams	2 ms	3 ms	Output: recommended via digital outputs
High-precision cam	300 µs	350 µs	Output: only via digital outputs
Synchronous actions	6 ms	9 ms	
S7 cycle time (without user program)	2 ms	6 ms	For one FM 357-2
S7 cycle time (without user program)	3 ms	7 ms	For two FM 357-2s
Read/write NC variables	3 ms	15 ms	Dependent on number and data quantity
Specify axis position (PLC positioning axis)	2 ms	7 ms	
Select program	3 ms	8 ms	

Data Storage

The data can either be stored on the start-up PG/PC or on the S7-300 memory card. The FM 357-2 is capable of reading from or writing to a memory card. During operation, the memory card must be inserted in the module.

When storing the data on the memory card a module replacement or series commissioning is possible without a PG/PC.

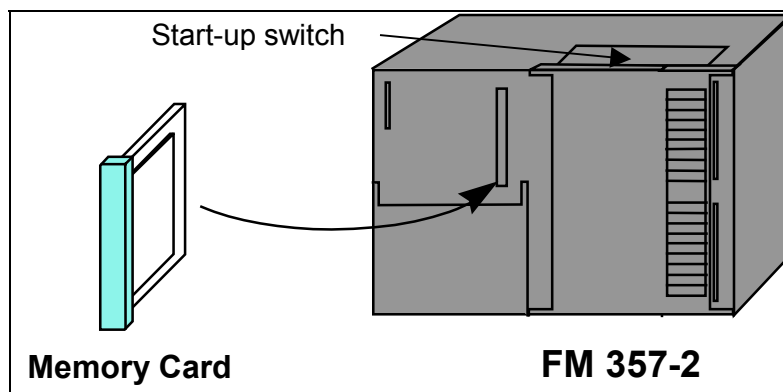

(Memory Card for data storage)

Data that is stored in the internal program memory is backed up by a battery and is therefore protected in case of a power loss.

Start-up

General

During Start-up the following steps have to be carried out:

1. Ensure that the electrical and mechanical setup is correct
2. Start up the drive and set the parameters
3. Connect a PG/PC to the MPI interface on the CPU
4. Load the system firmware on the FM 357-2 via memory card
5. Load the S7 Technology blocks on the S7-CPU and call them in the cyclical program
6. Start the FM 357-2 parameterization tool from the S7 Hardware Configuration
7. Use the parameterization wizard to guide you through setting parameters for the FM 357-2
8. After reference point approach (if necessary), test the single axes with the start-up screen and load or create a motion program (if required).

The FM 357-2 also provides a test mode (setting: "Simulation") where the controller is simulated without drive operation.

Operating modes

The FM 357-2 positioning module can be operated in several modes. They can be selected in the S7 user program or in the start-up screen:

- **Automatic mode**
In this mode a program in the FM 357-2 is executed sequentially. A program must be selected before it can be started.
Other programs can be created or edited at the same time using the start-up tool.
- **Automatic single-block mode**
An existing program is selected and then executed line by line, that is in single blocks.
The program stops after each block and must be started again.
- **MDI (manual data input) mode**
Program lines (blocks) can be entered directly via the parameterization tool and immediately executed one by one.
- **Jog mode**
Every single motion axes can be controlled separately by keys.
- **Incremental mode**
Single axes can be traversed manually in incremental mode.
- **Reference point approach (homing)**
Referencing of the axes can be triggered manually or automatically (with incremental encoders or stepper motors).

In conjunction with a handheld programming unit or handheld terminal, the FM 357-2 H version also supports the "teach-in" function commonly used in robotics (for more information, please refer to our separate datasheet).

Drives which are difficult or impossible to control can be operated in the **controlled mode** by specifying a speed setpoint.

Monitoring functions

Several internal monitoring functions are provided to ensure safe operation. A wide range of settings are available via the parameterization tool or the program:

The following can be monitored:

- Correct approach to the position
- Motions in programmed standstill
- Following error (path deviations during traversal)
- Traversing speed for maximum values
- Encoder hardware
- With stepper motors: rotation monitoring via cyclical signals
- Hardware and software limit switches

Alarm messages can be stored in the S7-CPU in plain text. They can be output, for example, on OPs.

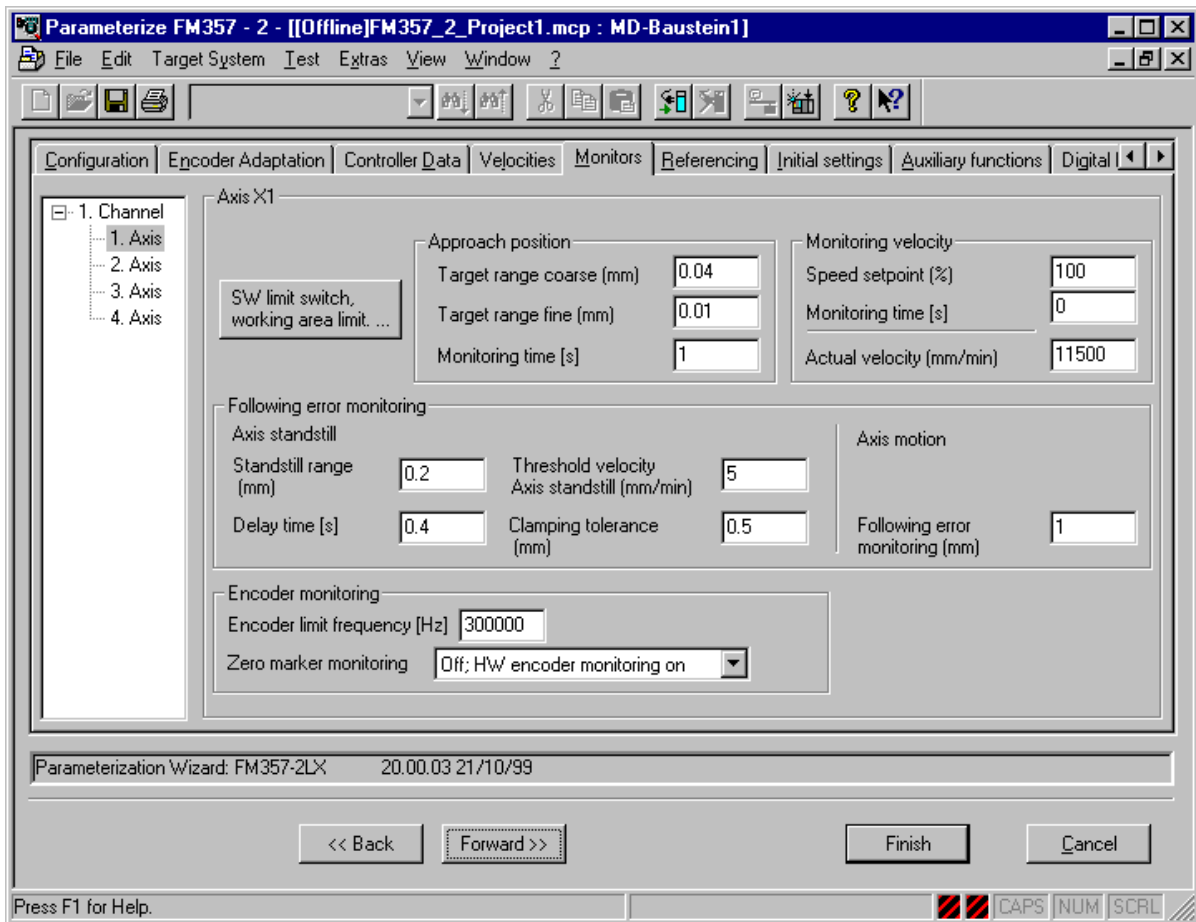

(Parameterization wizard: setting the monitoring functions)

Technical Data

General data

Supply voltage	20.4...28.8 V
Power consumption	24 W
Backplane bus load	100 mA
Dimensions (WxHxD) in mm	200 x 125 x 118
Weight, approx.	1.2 kg
Degree of protection acc. to DIN 40050	IP 20
Certification	CE, UL, CSA
Program memory	approx. 770 KB
Memory type	Retentive, battery backup (> 7 years)
Data backup	Short S7-300 on-board memory card or via parameterization tool
Number of program instructions	Limited by memory capacity only
Max. number of arithmetic parameters	> 1,000
Programming language	DIN 66025
Subroutine levels	7
Number of subroutine passes	< 9,999
Cycle time interpolator	9 ms
Cycle time servo	3 ms
Coordinate systems	Cartesian, polar
Dimensions	Inch/metric
Axes/measuring circuits	4
Documentation	Contained in configuration package; also online help in parameterization tool
Export	The FM 357-2 LX and 357-2 H firmware versions are subject to export restrictions and require export approval outside the EU (AG 11, SAG2044946) Version FM 357-2 L has no export restrictions

Motion control

Interpolation	Max. of 4 axes
Single axis positioning	Max. of 4 independent axes, available soon with interpolation groupings (e.g. 3+1)
Mode groups/channels	4
Maximum traversing velocity	300 m/s
Max. traversing range	± 9 decades
Override functions	0% to 200%
Acceleration	Linear, jerk limitation (\sin^2), knee-shaped (stepper drives)

HMI

Native protocol linking with expanded functions	SIMATIC HMI OP7 / OP17
Data server with direct communication	SIMATIC HMI
Connection via S7-CPU	All SIMATIC HMI components
Start-up	"FM Param" tool (configuration package) on PG/PC separate standalone editor "Edit-FM"

SIMATIC system data

Max. number of FM 357-2 modules on one CPU	3
Communication with S7 user program	S7 technology blocks (FB, FC, DB)
STEP 7	Version 4.02 and higher
Memory requirements	approx. 10 KB for minimum, approx. 16 KB for full communication with the FM357-2 for additional FM 357-2: approx. 800 bytes in addition
Supported CPUs	CPU 314 IFM, CPU 315, CPU 315-2 DP, CPU 316, CPU 318, CPU 614 C7-626, C7-626 DP, C7-333, C7-334
Distributed I/Os ET 200	IM 153-2 / ET 200M (reduced performance)
S7 program cycle time	< 10 ms

Drive technology

Supported drives	SIMODRIVE 611U servo drives via PROFIBUS DP with MC-Expansions ^{*)} or ± 10 V interface, POSMO C and POSMO SI with clock-cycle synchronous PROFIBUS DP ^{*)} stepper drives with TTL interface, frequency converter with vector control (on request), hydraulics module with servo valves (on request) ^{*)} PROFIBUS DP not possible with Firmware Version H in combination with a PHG or HT 6
Connectors	50-pin Sub-D connector for all outputs, 4x15-pin Sub-D connector for encoder inputs
Supported encoders	Incremental (TTL) or absolute (SSI), also in conjunction with stepper drives, EnDat – via SIMODRIVE 611U and PROFIBUS or POSMO C and SI Second encoder with PROFIBUS drives possible
Max. frequency for stepper motors	750 kHz
Voltage level on the stepper motor output	5 V (TTL) for clock pulses and direction signal
Max. cable length for stepper motors	50 m, (35 m in hybrid operation with servo axes)
Number of steps for stepper drives	500–10,000 (FM STEPDRIVE, can be set on power converter)

Ordering data

Components	Order No.
SIMATIC FM 357-2 Hardware	6ES7 357-4AH01-0AE0
Front screw connector	6ES7 392-1AM00-0AA0
FM 357-2 L, system firmware on coded memory card incl. configuration package (German, English, French, Italian) *)	6ES7 357-4AH03-3AE0
FM 357-2 LX, system firmware on coded memory card incl. configuration package (German, English, French, Italian) *)	6ES7 357-4BH03-3AE0
FM 357-2 Handling, system firmware on coded memory card incl. configuration package (German, English, French, Italian) *)	6ES7 357-4CH03-3AE0
*) The configuration package for the FM 357-2 L, LX, H contains: parameterization tool, S7 technology blocks, screen forms for OP17 and OP27, documentation on CD-ROM	
Printed manual for FM 357-2	
German	6ES7 357-4AH00-8AG0
English	6ES7 357-4AH00-8BG0
French	6ES7 357-4AH00-8CG0
Italian	6ES7 357-4AH00-8EG0
Edit-FM - standalone editor for NC programs	6FC5 263-0AA03-0AB0
FM/NC channel (channel DLL) for WINCC	On request
Supported encoders	
Absolute encoder 6FX2 001-5...	See Catalog NC 60
Incremental encoder 6FX 2001-2	See Catalog NC 60
SIMATIC S7 Components:	
CPUs, Power supplies and accessories	See Catalog ST 70
I/O and Function modules	See Catalog ST 70

