

 **MITSUBISHI**
PROGRAMMABLE CONTROLLERS
MELSEC-F

USER'S MANUAL

FX_{2N}-16LNK-M MELSEC-I/O LINK
REMOTE I/O SYSTEM MASTER BLOCK

FX_{2N}



Foreword

- This manual contains text, diagrams and explanations which will guide the reader in the correct installation and operation of the FX_{2N}-16LNK-M MELSEC-I/O LINK REMOTE I/O SYSTEM MASTER BLOCK. It should be read and understood before attempting to install or use the unit.
Further information can be found in the FX PROGRAMMING MANUAL, FX_{2N} series hardware manuals.
- If in doubt at any stage during the installation of the FX_{2N}-16LNK-M MELSEC-I/O LINK REMOTE I/O SYSTEM MASTER BLOCK always consult a professional electrical engineer who is qualified and trained to the local and national standards.
If in doubt about the operation or use of the FX_{2N}-16LNK-M MELSEC-I/O LINK REMOTE I/O SYSTEM MASTER BLOCK please consult the nearest MITSUBISHI ELECTRIC distributor.
- This manual is subject to change without notice.



FX₂N-16LNK-M MELSEC-I/O LINK REMOTE I/O SYSTEM MASTER BLOCK

USER'S MANUAL

Manual number : JY992D73701
Manual revision : B
Date : OCTOBER 1998

Guidelines for the safety of the user and protection of the FX_{2N}-16LNK-M MELSEC-I/O LINK SYSTEM MASTER BLOCK

This manual provides information for the installation and use of the FX_{2N}-16LNK-M MELSEC-I/O LINK SYSTEM MASTER BLOCK. The manual has been written to be used by trained and competent personnel. The definition of such a person or persons is as follows;

- a) Any engineer who is responsible for the planning, design and construction of automatic equipment using the product associated with this manual should be of a competent nature, (trained and qualified to the local and national standards required to fulfill that role). These engineers should be fully aware of safety with regards to automated equipment.
- b) Any commissioning or service engineer must be of a competent nature, trained and qualified to the local and national standards required to fulfill that job. These engineers should also be trained in the use and maintenance of the completed product. This includes being completely familiar with all associated documentation for the said product. All maintenance should be carried out in accordance with established safety practices.
- c) All operators of the compliance product should be trained to use that product in a safe and coordinated manner in compliance to established safety practices. The operators should also be familiar with all documentation which is connected with the actual operation of the completed equipment.

Note: The term 'completed equipment' refers to a third party constructed device which contains or uses the product associated with this manual.

Note's on the symbology used in this manual

At various times through out this manual certain symbols will be used to highlight points of information which are intended to ensure the users personal safety and protect the integrity of the equipment. Whenever any of the following symbols are encountered, its associated note must be read and understood. Each of the symbols used will now be listed with a brief description of its meaning.

Hardware warnings



1) Indicates that the identified danger **WILL** cause physical and property damage.



2) Indicates that the identified danger **POSSIBLY** cause physical and property damage.



3) Indicates a point of further interest or further explanation.

Software warnings



1) Indicates special care must be taken when using this element of software.



2) Indicates a special point of which the user of the associate software element should be aware.



3) Indicates a point of interest or further explanation.

Memo

CONTENTS

1. Notes to User	1-1
1.1 Outline of product	1-1
1.2 Manual configuration and diversified data	1-2
2. Product Specifications	2-1
2.1 System configuration	2-1
2.2 Appearance and name of each portion	2-3
2.3 General specifications and performance specifications	2-4
3. Connection and Wiring	3-1
3.1 Cautions on connection	3-1
3.2 Connection method	3-7
4. Operation	4-1
4.1 Operating procedure	4-1
4.2 Setting and function of each portion	4-2
4.3 Setting of station No.	4-7
4.4 Program	4-8
5. Troubleshooting	5-1
6. Remote I/O Unit	6-1
6.1 Model name structure	6-1
6.2 Outside dimensions	6-2
Appendix	A-1

MEMO

1. Notes to User

1.1 Outline of product

The MELSEC-I/O LINK REMOTE I/O SYSTEM MASTER BLOCK FX_{2N}-16LNK-M (hereinafter referred to as "master block") is connected to an FX_{0N}/FX_{2N}/FX_{2NC} Series programmable controller (PC), and realizes a remote I/O system which saves wiring and enables easy programming for communication with remote I/O units.

Applicable PC

The master block can be connected as a special block of an FX_{0N}/FX_{2N}/FX_{2NC} Series PC.

When it is connected to an FX_{2NC} Series PC, a connector conversion interface FX_{2NC}-CNV-IF is required.

Features

- 1) Many control points
One master block can control up to 128 points (64 input points and 64 output points) (when mixed I/O type remote I/O units having 8 or 16 control points are used).
To one master block, up to 16 remote I/O units can be connected.
- 2) Wiring saving
A master block and a remote I/O unit can be easily connected with a twisted-pair or cabtyre cable.
- 3) Total extension distance: 200 m
The distance can be extended up to 200 m in the entire system.
Terminal resistors are not required, and connection using T branches can be realized.
- 4) Free from system down caused by failure in one station
Even if failure has occurred in a remote station in the system, the system does not come down.
Diversified error indication LEDs facilitate quick troubleshooting.
- 5) Easy programming
Element Nos. for inputs (X) and outputs (Y) are assigned to remote I/O units in the same way as general I/Os.
Communication programs are not required.

1.2 Manual configuration and diversified data

This user manual exclusively is packed together with the master block.

For programs in a basic PC unit, handling of remote I/O units, etc., refer to the corresponding data.

User manual (this manual)

This manual describes cautions on safety, specifications, attachment and wiring of the master block, programming and troubleshooting.

User manual of MELSEC-I/O LINK REMOTE I/O SYSTEM MASTER UNIT AJ51T64/A1SJ51T64 (detailed volume)

This manual describes the specifications of remote I/O units connected to the master block.

2. Product Specifications

2.1 System configuration

Example of system configuration

- Basic unit
FX0N/FX2N/FX2NC Series

FX2NC-CNV-IF is required when FX2NC is connected.

- I/O link master block FX2N-16LNK-M

*1: Extension unit, extension block, special extension unit or special extension block

*2 Remote I/O unit

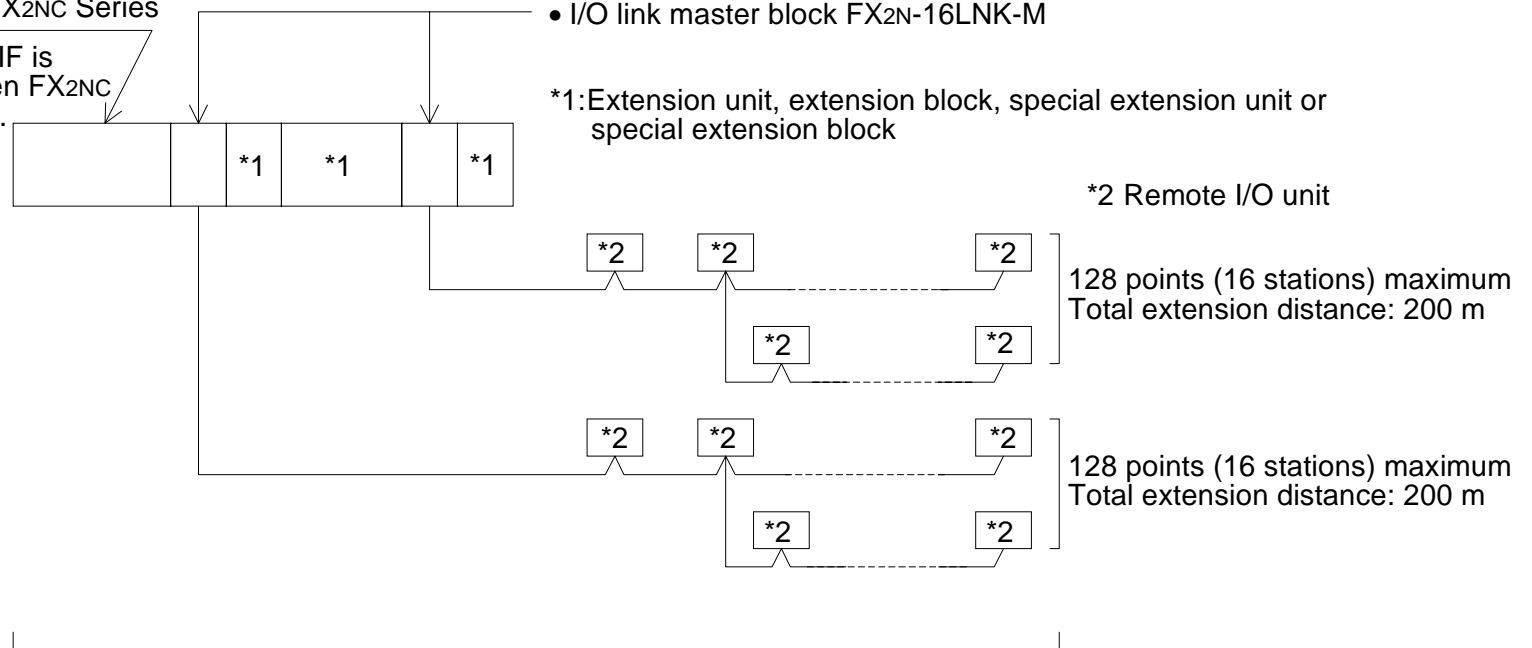

Number of maximum I/O points: FX0N 128 points } The number of I/O points include a basic unit, extension
 FX2N 256 points } units/blocks, special extension units/blocks and remote
 FX2NC 256 points } I/O units.

Number of connected master blocks

The number of connected master blocks can be arbitrary as far as the total number of I/O points of a basic unit, master blocks, extension units/blocks and special extension units/blocks (occupying eight input or output points) satisfies the following.

FX_{0N} :128 points \geq I/O points of basic unit + I/O points of extension units/blocks +
(I/O points of special extension units/blocks x 8) + I/O points occupied by master blocks

FX_{2N} or FX_{2NC} :256 points \geq Same above

However, one master block consumes 200 mA of 5 VDC power supply (which corresponds to 64 I/O points in the case of FX_{2NC}). When determining the number of master blocks connected to a basic unit and extension units, refer to the handy manual of the basic unit.

2.2 Appearance and name of each portion

- Face painting color: Munsell 0.08GY/7.64/0.81
- Weight: 0.5 kg

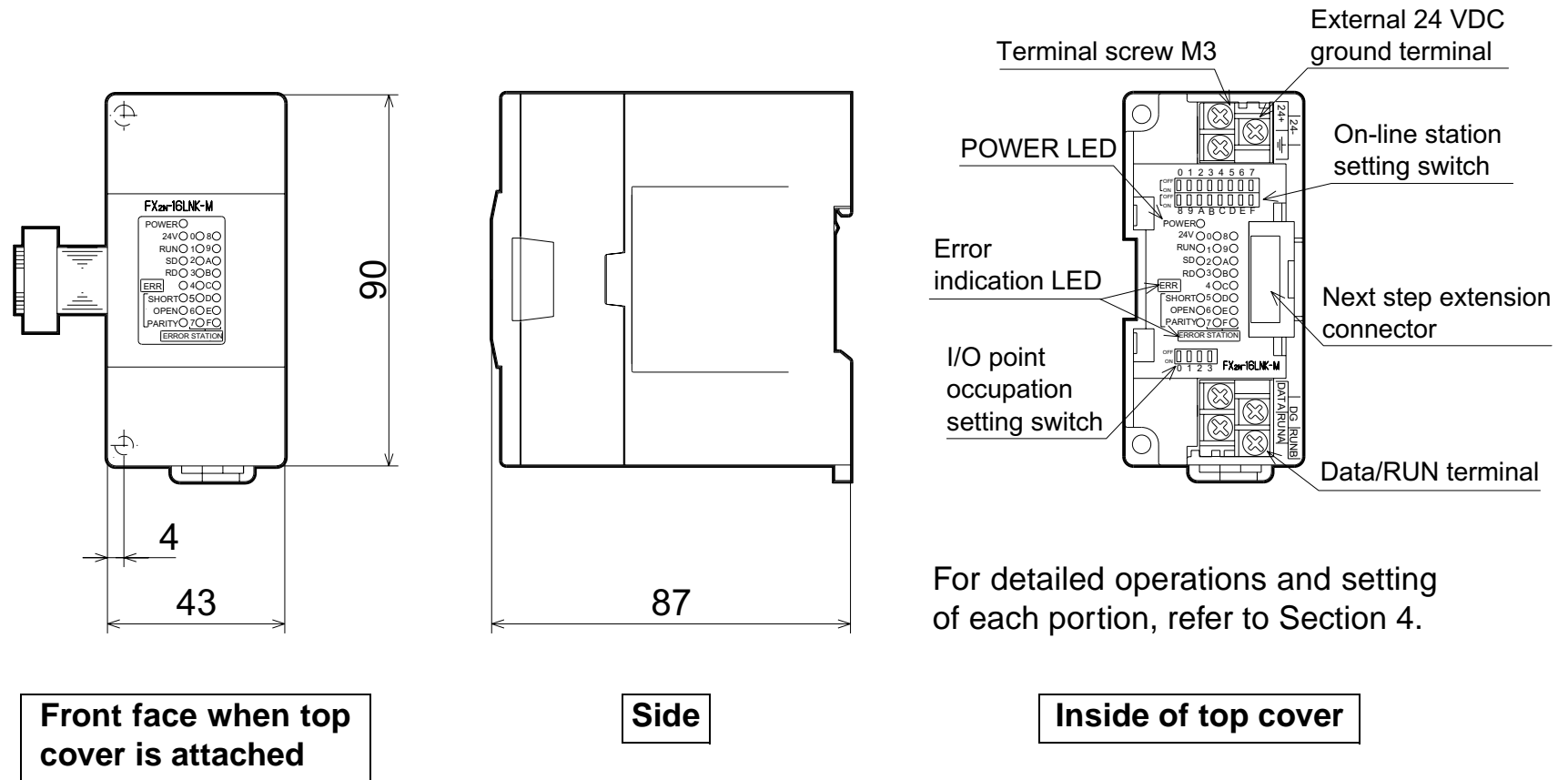

2.3 General specifications and performance specifications

General specifications

Specifications item		Description
Ambient temperature	During operation	0 to 55°C
	During storage	-20 to 70°C
Ambient humidity	During operation	35 to 85%RH (no condensation)
	During storage	35 to 90%RH (no condensation)
Vibration resistance		In conformance to JIS-C0911 (Vibration frequency 10 to 55 Hz, 0.5 mm (2 G max.), 2 hours in each of three axis directions)*
Impact resistance		In conformance to JIS-C0912 (10 G, three times in each of three axis directions)
Noise resistance		By noise simulator whose noise voltage is 1,000 Vp-p, noise width is 1 μs and frequency is 30 to 100 Hz
Withstand voltage		1,500 VAC, 1 min
Insulation resistance		5 MΩ or more by 500 VDC megger
Grounding		Class 3 grounding (Common grounding with a strong electrical system is not allowed.)
Ambient atmosphere		Free from corrosive gas, flammable gas and much conductive dusts

* 0.5 G when DIN rails are used for attachment

Performance specifications

Specifications item		Description
Maximum number of controlled I/O points		128 points (16 remote units with 4 points each) per master block
I/O refresh time		Approx. 5.4 ms (without regard to number of I/O points)
Communication speed		38400 bps
Communication method		Register insertion method
Synchronization method		Frame synchronization and bit synchronization used together
Communication specifications	Error control method	Adjacent phase inversion check and parity check used together (retry by timeout)
	Transmission path type	Bus (multi-drop) type (T branches are available. Terminal resistors are not required.)
	Transmission distance	Maximum total extension distance: 200 m
	Maximum number of connected units	16 stations per master block
Error (RUN) indication/output		Indication by LEDs
		Confirmation of 24V DC power supplied from outside to master block by M8009 (24V DC down) in basic unit
		External outputs by RUNA and RUNB
Number of occupied I/O points		Selectable among 16, 32, 48, 64, 96 and 128
Supply voltage from outside		21.6 to 27.6V DC (for communication path)
Current consumption of power supply from outside		90 mA (TYP 24V DC)
Current consumption inside (5 VDC)		200 mA
Weight		0.5 kg

Cable specifications

Specifications item	Description	
Cable type	Shielded twisted-pair cable	Cabtyre cable *
Logarithm	0.75 mm ² × 1P	0.75 mm ² × 2C
Conductive resistance (20°C)	29 Ω/km or less	
Electrostatic capacity (1 kHz)	75 nF/km or less	—
Characteristic impedance (100 kHz)	100 Ω (average)	—
Insulation resistance	500MΩ/km or more	
Withstand voltage	500V AC for 1 min or more	
Outer diameter	∅ 8.5 mm or less	∅ 9 mm or less

* Cabtyre cables are weaker against noises than shielded cables.

- Recommended cables
The table below shows the model names, the specifications and the manufacturer of recommended cables.

Recommended cables

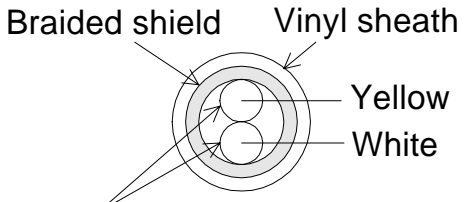
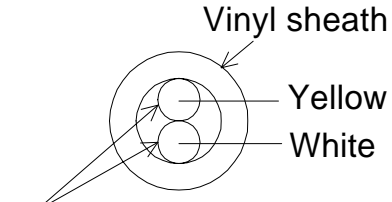
Item	Specifications	
Model name	KNPEV-SB 0.75SQ×1P	KNEV 0.75SQ×2C
Cable type	Shielded twisted-pair cable	Unshielded cabtyre cable
Logarithm	0.75 mm ² × 1P	0.75 mm ² × 2C
Conductor resistance (20°C)	26.3 Ω/km or less	
Electrostatic capacity (1 kHz)	60 nF/km or less	—
Specific impedance (1,000 kHz)	90 Ω (average)	—
Insulation resistance	10,000 MΩ or more	
Withstand voltage	1000V AC	
Cross section	 <p>A pair of insulating conductors 0.75 mm² PE</p>	 <p>Two cores of insulating conductors 0.75 mm² PE</p>
Outer diameter	∅ 7.5 mm or less	∅ 7 mm or less

Model name	Type
SPEV(SB)-0.75-1P	Shielded twisted-pair cable (1 P)
KMPEV-SB CWS-178 0.75SQ×1P	Shielded twisted-pair cable (1 P)
2PNCT 0.75SQ×2C	Two-cored cabtyre cable
DPEV SB 0.75×1P	Shielded twisted-pair cable (1 P)
VCT 0.75×2C	Two-cored cabtyre cable
D-KPEV-SB 0.75×1P	Shielded twisted-pair cable (1 P)
IPEV-SB 1P×0.75	Shielded twisted-pair cable (1 P)

3. Connection and Wiring

3.1 Cautions on connection

Cautions on design



- Construct interlock circuits on a sequence program so that the system operates conservatively when a communication error has occurred in a data link. If the system does not operate conservatively, an accident may be caused by erroneous outputs and/or malfunction.



- Never bind control cables and communication cables together with power cables. Never locate control cables and communication cables near major circuits. Keep the distance of 100 mm or more. If sufficient distance is not kept, malfunction may be caused by noises.

Cautions on system configuration

Pay attention to the following points in the power supply wiring (system design) so that erroneous inputs to remote I/O units can be prevented.

- 1) Countermeasures against erroneous inputs occurred when the power is turned on or off
 - When the power is turned on
 - [Draft 1] Turn on at first the power of remote I/O units and the power of master blocks supplied from the outside. Then, turn on the power of a basic PC unit.
 - [Draft 2] Turn on at the same time the power of remote I/O units, the power of master blocks supplied from the outside and the power of a basic PC unit.
 - When the power is turned off
 - [Draft 1] Turn off at first the power of a basic PC unit. Then, turn off the power of remote I/O units and the power of master blocks supplied from the outside.
 - [Draft 2] Turn off at the same time the power of a basic PC unit and the power of master blocks supplied from the outside.
- 2) Countermeasures against erroneous inputs occurred when the power of a remote I/O unit is instantaneously interrupted

If the power of a remote I/O unit is instantaneously interrupted, erroneous inputs may occur.

 - Causes of erroneous inputs by instantaneous power interruption

The hardware of a remote I/O unit converts the I/O unit power supply (24V DC) into 5V DC inside, then uses it.

If the power of a remote I/O unit is instantaneously interrupted, the following relationship is generated.

(Time until 5V DC inside remote I/O unit is turned off) < (Response time of input unit ON → OFF)

Accordingly, if I/O refresh occurs within the time shown as ① in the figure below, erroneous inputs occur.

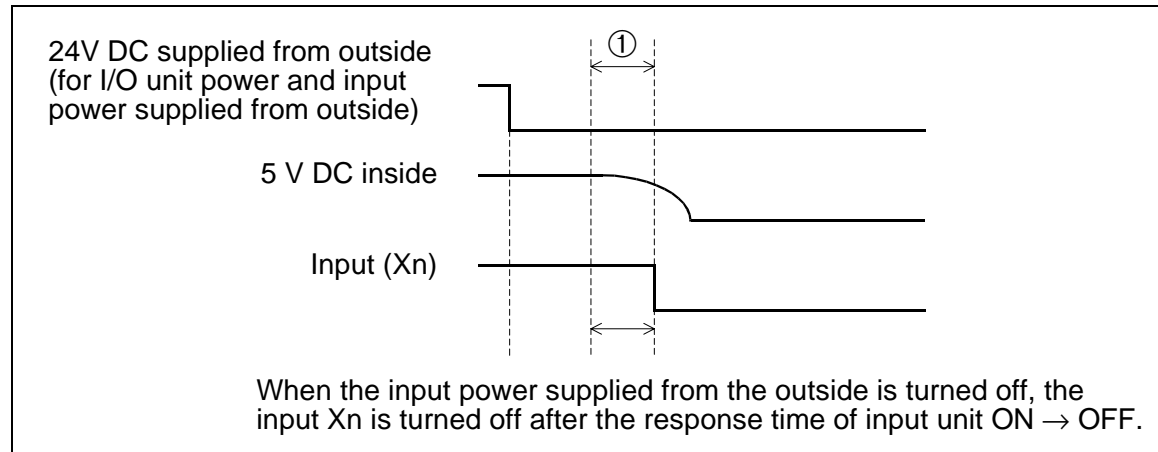

Countermeasures against erroneous inputs

Perform wiring of a PC unit and a stabilized power supply unit from a same power supply.

- When the 24V DC service power supply of a PC unit is used
FX_{0N}/FX_{2N} Series AC power supply type

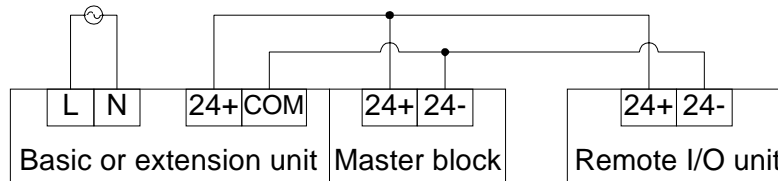

When the 24V DC service power supply of a basic unit or an extension unit is used, pay attention so that the capacity of 24V DC power supply built in each unit is not exceeded. For calculation of the capacity of the service power supply, refer to the handy manual supplied together with the basic unit.

When an FX_{0N} Series PC is connected, running of a master block is instantaneously interrupted approximately 2 sec after the power to the master block is turned on. It is recommended to read the information on data/RUN terminal of a remote I/O unit 3 sec after the power is turned on.

- When a stabilized power supply unit is used
FX_{0N}/FX_{2N} Series AC power supply type

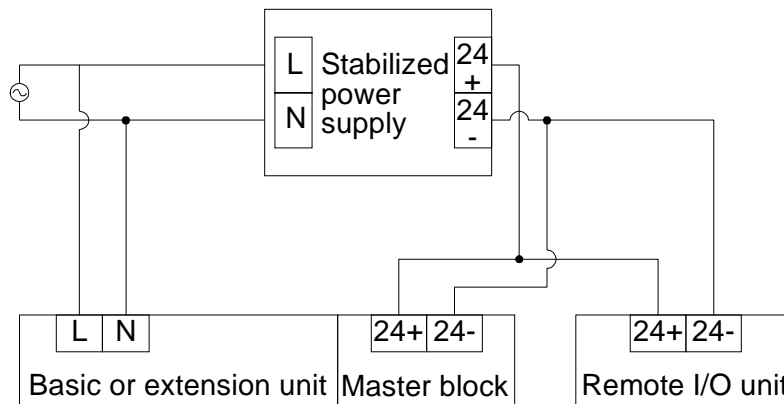

FX₀N/FX₂N Series DC power supply type

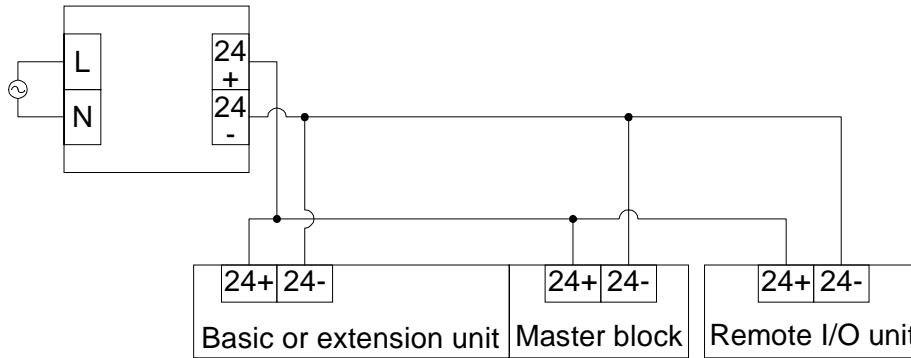

FX₂NC Series (DC power supply type)

When an FX₂NC Series PC is combined and used in an environment with much noises, provide a noise filter between a DC power supply and the FX₂NC PC. (At this time, do not ground the ground terminal of the FX₂NC PC.)

Recommended noise filter: ZHG2203-11S manufactured by TDK

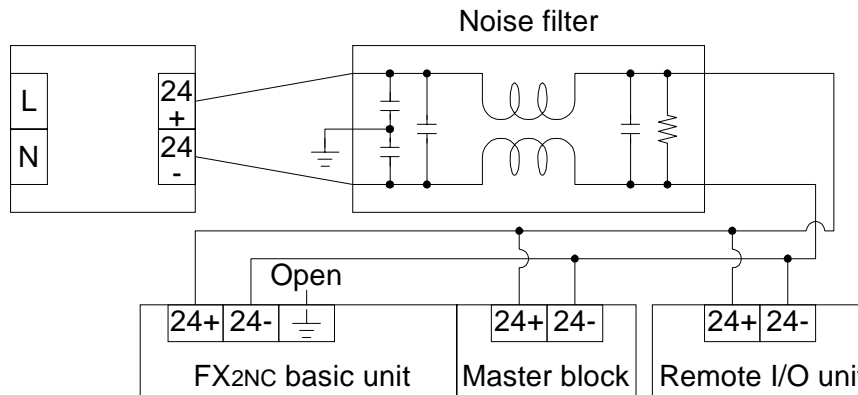

Grounding

- When grounding the FG terminal, use a wire as thick as possible (2.0 mm²). Perform grounding as shown below. Never perform common grounding with equipment with high frequency.

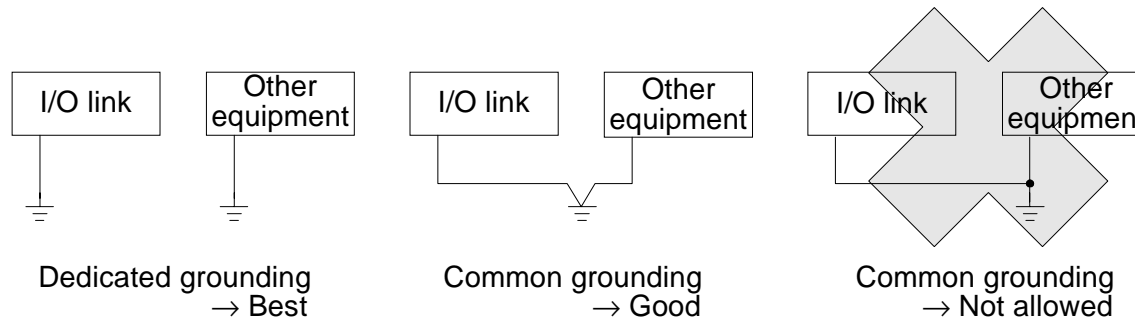

- When shielded twisted-pair cables are used, transmitted waveforms may be affected by the ground condition and communication errors may occur in a long-distance system. The effects given by shield grounding is determined by the number of connected remote I/O units and the total extension distance. If the relationship shown in the table below is realized, do not perform grounding. (For details, refer to the next page.)

Number of connected remote I/O units	1	2	3	4	5	6	7	8	9	10	11~12	13~15	16
Minimum total extension distance	—	150	130	110	100	90	85	75	70	65	60	55	50

The number of connected remote I/O units above does not mean the number of stations. When cabtyre cables are used, transmitted waveforms are not affected by the ground condition because shield is not provided.

3.2 Connection method

The figures below show the connection diagrams with twisted-pair cables and cabtyre cables respectively.

Connection with twisted-pair cables

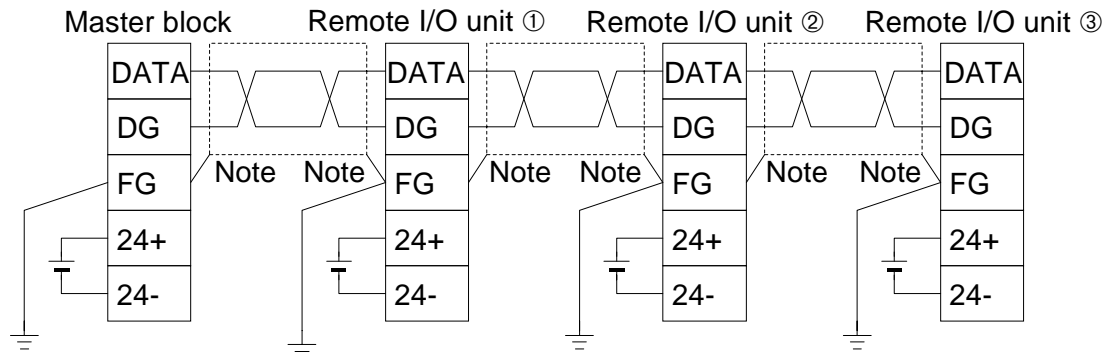

Note:

Refer to "Grounding" on the previous page, confirm the number of connected remote I/O units and the total extension distance, then perform grounding of shields.

Connection with cabtyre cables

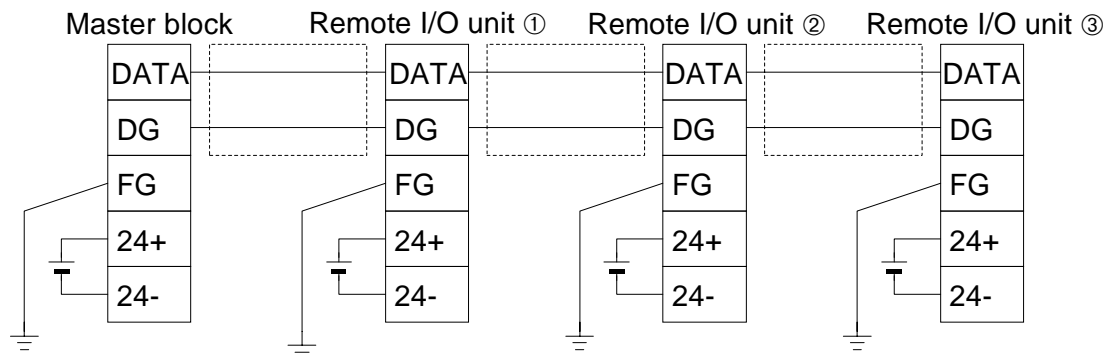

- If 24V DC is applied on signal lines (DATA and DG) by mistake, the unit is damaged. Make sure that the cables are correctly connected before turning on the power (24V DC) supplied from the outside.

Reference

When two or more units are supplied from one power supply unit, make sure that the voltage required by each unit is satisfied.

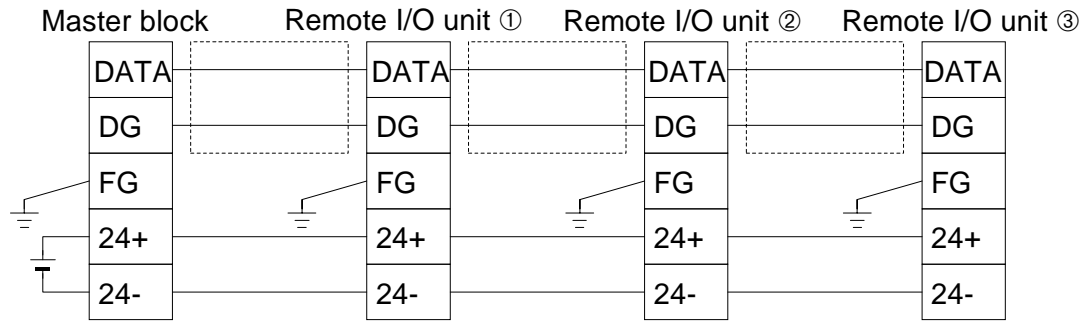

Connection with T branches

The figure below shows a connection diagram using T branches. Method to branch transmission lines on the midway

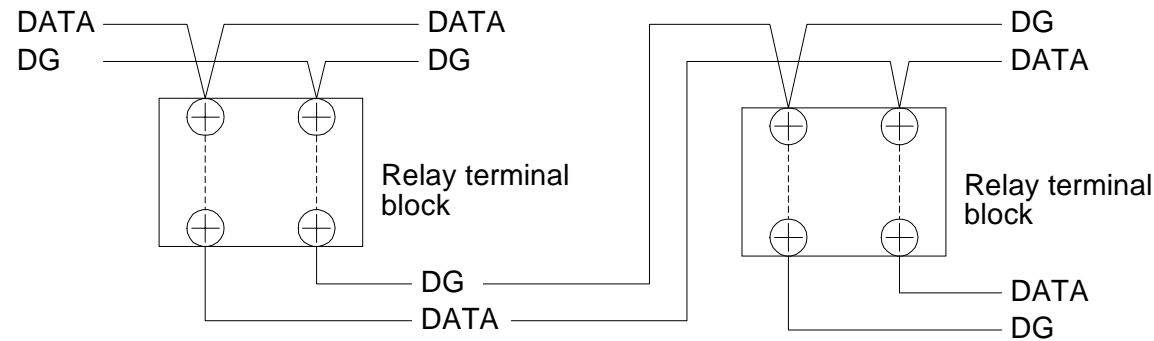

T-branched transmission lines can be T-branched further more. (as far as the total extension distance is 200 m or less.)

4. Operation

4.1 Operating procedure

The flowchart below shows the operating procedure.

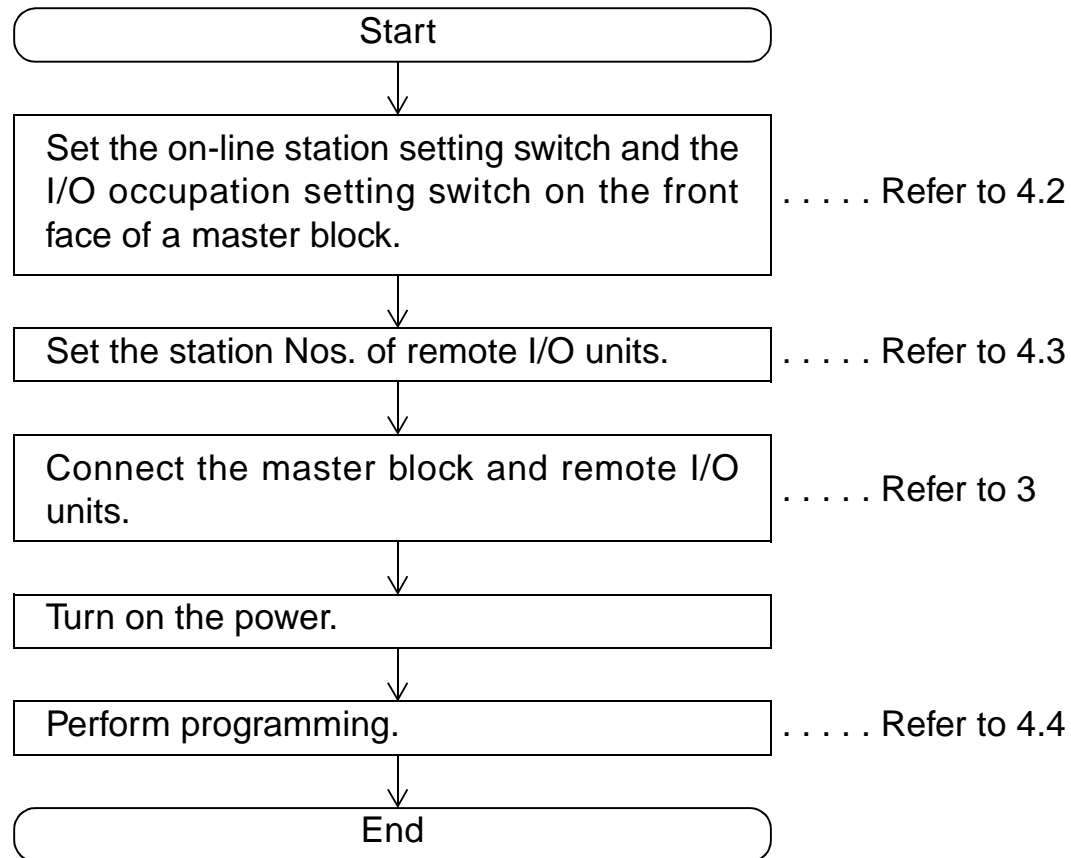

4.2 Setting and function of each portion

The table below shows the setting contents and the function of each setting switch provided on a master block.

For layout of the each setting switch, refer to Paragraph 2.2.

Setting switches

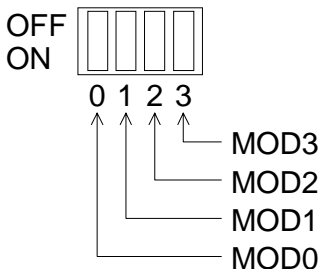
Name	Description																																														
<p>I/O point occupation setting switch</p> 	<p>Set the number of points occupied by a master block.</p> <table border="1" style="width: 100%; border-collapse: collapse;"> <thead> <tr> <th colspan="2" style="background-color: #d3d3d3;">MOD2</th> <th style="background-color: #d3d3d3;">MOD0</th> <th style="background-color: #d3d3d3;">MOD1</th> <th style="background-color: #d3d3d3;">Number of occupied points</th> <th style="background-color: #d3d3d3;">Default value</th> </tr> </thead> <tbody> <tr> <td rowspan="4" style="text-align: center; vertical-align: middle;">ON</td> <td rowspan="4" style="text-align: center; vertical-align: middle;">Standard mode</td> <td style="text-align: center;">ON</td> <td style="text-align: center;">ON</td> <td style="text-align: center;">128 points</td> <td style="text-align: center;">○</td> </tr> <tr> <td style="text-align: center;">OFF</td> <td style="text-align: center;">ON</td> <td style="text-align: center;">96 points</td> <td></td> </tr> <tr> <td style="text-align: center;">ON</td> <td style="text-align: center;">OFF</td> <td style="text-align: center;">64 points</td> <td></td> </tr> <tr> <td style="text-align: center;">OFF</td> <td style="text-align: center;">OFF</td> <td style="text-align: center;">32 points</td> <td></td> </tr> <tr> <td rowspan="4" style="text-align: center; vertical-align: middle;">OFF</td> <td rowspan="4" style="text-align: center; vertical-align: middle;">Dedicated I/O type unit mode</td> <td style="text-align: center;">ON</td> <td style="text-align: center;">ON</td> <td style="text-align: center;">64 points</td> <td></td> </tr> <tr> <td style="text-align: center;">OFF</td> <td style="text-align: center;">ON</td> <td style="text-align: center;">48 points</td> <td></td> </tr> <tr> <td style="text-align: center;">ON</td> <td style="text-align: center;">OFF</td> <td style="text-align: center;">32 points</td> <td></td> </tr> <tr> <td style="text-align: center;">OFF</td> <td style="text-align: center;">OFF</td> <td style="text-align: center;">16 points</td> <td></td> </tr> </tbody> </table> <p>The number of occupied points indicates the number of points used by the I/O link system. The number of points of connected remote I/O units is equivalent to or smaller than this. Use the standard mode usually. If remote I/O units dedicated to input or output are used, the dedicated I/O type unit mode is also available. MOD3 is not used.</p>					MOD2		MOD0	MOD1	Number of occupied points	Default value	ON	Standard mode	ON	ON	128 points	○	OFF	ON	96 points		ON	OFF	64 points		OFF	OFF	32 points		OFF	Dedicated I/O type unit mode	ON	ON	64 points		OFF	ON	48 points		ON	OFF	32 points		OFF	OFF	16 points	
MOD2		MOD0	MOD1	Number of occupied points	Default value																																										
ON	Standard mode	ON	ON	128 points	○																																										
		OFF	ON	96 points																																											
		ON	OFF	64 points																																											
		OFF	OFF	32 points																																											
OFF	Dedicated I/O type unit mode	ON	ON	64 points																																											
		OFF	ON	48 points																																											
		ON	OFF	32 points																																											
		OFF	OFF	16 points																																											

Name	Description
<p>On-line station setting switch</p> <div style="display: flex; align-items: center; margin-left: 20px;"> <div style="margin-right: 10px;"> <p>0 1 2 3 4 5 6 7</p> <p>[OFF</p> <p>[ON</p> </div> <div style="display: flex; flex-direction: column; align-items: center;"> <div style="display: flex; gap: 5px;"> <div style="border: 1px solid black; width: 15px; height: 15px; margin: 2px;"></div> <div style="border: 1px solid black; width: 15px; height: 15px; margin: 2px;"></div> <div style="border: 1px solid black; width: 15px; height: 15px; margin: 2px;"></div> <div style="border: 1px solid black; width: 15px; height: 15px; margin: 2px;"></div> <div style="border: 1px solid black; width: 15px; height: 15px; margin: 2px;"></div> <div style="border: 1px solid black; width: 15px; height: 15px; margin: 2px;"></div> <div style="border: 1px solid black; width: 15px; height: 15px; margin: 2px;"></div> <div style="border: 1px solid black; width: 15px; height: 15px; margin: 2px;"></div> </div> <div style="margin-top: 5px;"> <div style="display: flex; gap: 5px;"> <div style="border: 1px solid black; width: 15px; height: 15px; margin: 2px;"></div> <div style="border: 1px solid black; width: 15px; height: 15px; margin: 2px;"></div> <div style="border: 1px solid black; width: 15px; height: 15px; margin: 2px;"></div> <div style="border: 1px solid black; width: 15px; height: 15px; margin: 2px;"></div> <div style="border: 1px solid black; width: 15px; height: 15px; margin: 2px;"></div> <div style="border: 1px solid black; width: 15px; height: 15px; margin: 2px;"></div> <div style="border: 1px solid black; width: 15px; height: 15px; margin: 2px;"></div> <div style="border: 1px solid black; width: 15px; height: 15px; margin: 2px;"></div> </div> </div> </div> <p style="margin-left: 20px; margin-top: 5px;">8 9 A B C D E F</p> </div>	<p>Set the station Nos. of connected remote I/O units. "0" to "F" indicate station Nos.</p> <p>ON: To be communicated (with error check)</p> <p>OFF: Not to be communicated (without error check)</p> <p>* Station Nos. are not necessarily serial numbers.</p> <p>If an unconnected station No. is set to OFF, communication error will not be indicated. (For setting of station Nos., refer to Paragraph 4.3.)</p> <p>If an unconnected station No. is set to ON, an error will occur in that station No. and the RUN terminals will be set to OFF. Make sure to set unused stations to OFF when the RUN terminals are used.</p>

LED indication and terminal block

Name		Status	Description	
LED POWER ○ 24V ○ 0 ○ 8 ○ RUN ○ 1 ○ 9 ○ SD ○ 2 ○ A ○ RD ○ 3 ○ B ○ ERR ○ 4 ○ C ○ SHORT ○ 5 ○ D ○ OPEN ○ 6 ○ E ○ PARITY ○ 7 ○ F ○ ERROR STATION	24 V	Lit	Supply voltage of power (24V DC) supplied from outside is normal.	
		Extin-guished	Supply voltage of power (24V DC) supplied from outside is insufficient.	
	RUN (*1)	Lit	SHORT, OPEN and PARITY errors have not occurred at all in any on-line station.	
		Extin-guished	SHORT, OPEN or PARITY error has occurred consecutively in six scans or more.	
	SD	Lit	Data is being sent.	
	RD (*2)	Lit	Data is being received.	
	ERR.	SHORT	Lit	DATA and DG are short-circuited.
		OPEN	Lit	When all data is adjacent inversion data (00) even in one on-line remote station, it is regarded as disconnection of transmission path, defect in remote I/O station or OFF of 24V DC power, and OPEN LED is lit.
		PARITY	Lit	When data is adjacent inversion data or parity check error data even in one on-line remote station, it is regarded as an error and PARITY LED is lit. When an open error has occurred, it is not regarded as a parity error.
	ERROR STATION	0 to F	Lit	When an open or parity error has occurred six times consecutively (X data is cleared at the same time.) or a status error has occurred in an online remote station, corresponding LED is lit (A fuse blowout error is issued at the same time.). When error status is cleared, LED is distinguished.

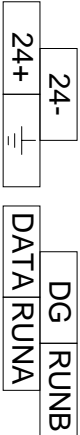
Name	Status	Description
Terminal block 	Connects signals, power supplies and RUN outputs (size: M3, tightening torque: 100 to 135 N•cm).	
	Name	Description
	DATA	Data
	DG	Data ground
	⊥	Ground
	24+	+24V DC power supply for transmission (plus side)
	24-	-24V DC power supply for transmission (minus side)
	RUNA RUNB	External output for lighting (or extinguished) status of RUN LED ON: RUN LED is lit.OFF: RUN LED is extinguished.

- *1 M8009: Checks status of the 24V DC power supplied from the outside when 24V DC has come down.
- *2 The brightness changes in accordance with the number of connected remote I/O units (As the number of units becomes larger, the LED becomes brighter.)

Terminals RUNA and RUNB

Indicator lamps can be attached outside a terminal block by utilizing these terminals so that it can be checked wither or not the I/O link system is correctly operating.

Rated current		2 A
Load voltage		250V AC, 30V DC (External commutating diode is required.)
Maximum load	Conductive load	80 VA 120/240V AC
	Ramp load	100 W 1.17A/85V AC 0.4A/250V AC
Leak current		—
Response time		Approx. 10 ms
Circuit isolation		Relay isolation
Circuit configuration		

4.3 Setting of station No.

This paragraph describes how to set the station No. of an remote I/O unit.

Remote I/O unit station No. setting (ST.NO.) switch

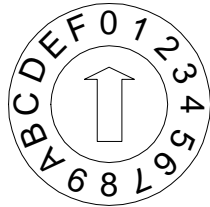

- Set the station No. within the range of 0 to F.
Station Nos. are not necessarily consecutive numbers. One station No. can be assigned to only one remote I/O unit.
- Set this switch to a desired station No. for a remote I/O unit, and turn on/off the on-line station setting switch provided on the master block.

4.4 Program

Set the station Nos., set the mode and perform wiring in accordance with "4.1 Operating procedure".
 Set the station Nos. and the mode using the following procedure.

Standard mode

- 1) Set the I/O occupation setting switch MOD2 to ON (initial value). I/O No. assignment in the standard mode is selected.
- 2) By turning on/off the switches MOD0 and MOD1, determine the number of I/O points occupied by the remote I/O system.
- 3) Assign a station No. and I/O Nos. to each remote I/O unit to be used. (Refer to the assignment table offered as attachment.)

When 128 points are occupied

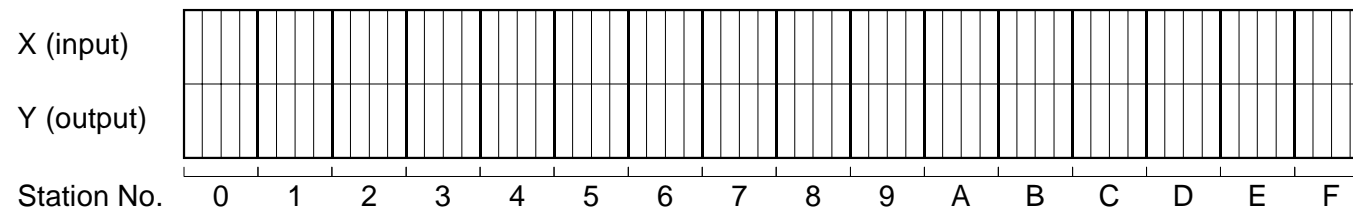

4) Assign remote I/O units to be used to the table above from the station No. 0 in turn.

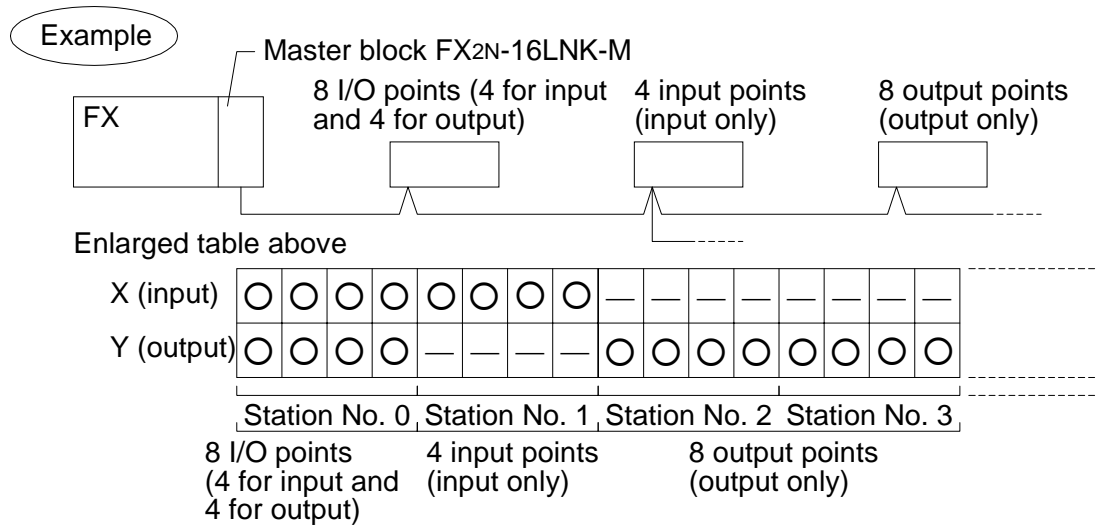

* Arbitrary number can be assigned as a station No. without regard to the wiring. In this example, the station No. 0 is assigned to a remote I/O unit nearest to the master block.

○: I/O No. is assigned.

—: Area occupied by remote I/O unit (I/O No. is not assigned.)

* Vacant numbers vary depending on used remote I/O units. For more information, refer to the attachment at the end of this manual.

- 5) Assign actual I/O Nos. to the assignment table shown on the previous page.
Assign I/O No. to each remote I/O unit from the I/O No. in the position in which a master block FX2N-16LNK-M is connected.

Example When 128 points are occupied

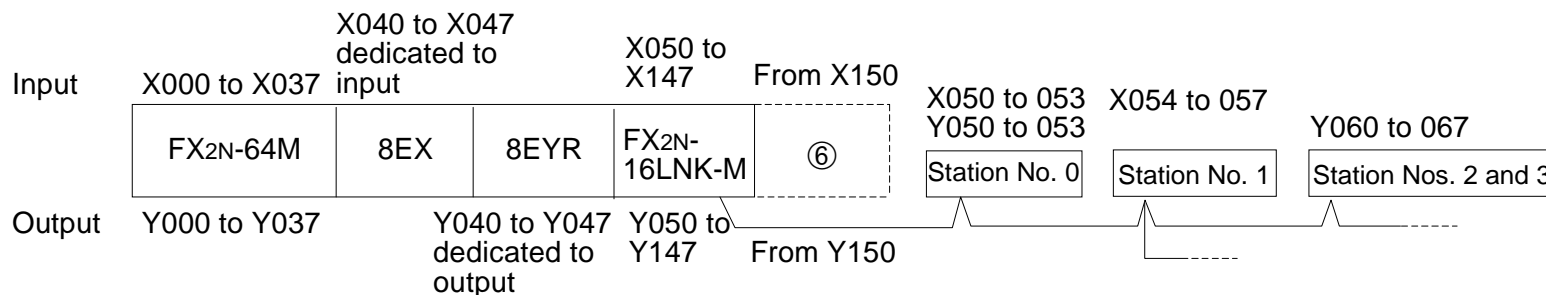

I/O assignment for remote I/O units

X (input)	50	51	52	53	54	55	56	57	—	—	—	—	—	—	—	—	70	-----	147
Y (output)	50	51	52	53	—	—	—	—	60	61	62	63	64	65	66	67	70	-----	147
	Station No. 0				Station No. 1				Station No. 2				Station No. 3						

- 6) When extension units and extension blocks are connected after the master block, I/O Nos. excluding the number of points occupied by the I/O occupation setting switches (MOD0 and MOD1) of the master block are assigned.
In the example above, input Nos. from X150 and output Nos. from Y150 are assigned.
Even if only one remote I/O unit is connected, the number of points occupied by the master block is not changed if the setting of the MOD0 and the MOD1 is not changed.
Accordingly, in the example above, input Nos. from X150 and output Nos. from Y150 are available even if the station No. 0 exclusively is provided.
- 7) When one station No. is set vacant, four input points and four output points are set vacant.

[Hint]

- When the available first input No. is not equivalent to the available first output No. in the position in which a master block is connected

In the example on the previous page, the available first input No. (X050) is equivalent to the available first output No. (Y050). The example below shows a case in which the available first input No. (X040) is not equivalent to the available first output No. (Y050). (Different from the example on the previous page, "8EX" is not provided in the example below.)

X (input)	40	41	42	43	44	45	46	47	—	—	—	—	—	—	—	—	—	60	-----	137
Y (output)	50	51	52	53	—	—	—	—	60	61	62	63	64	65	66	67	70	-----	147	
	Station No. 0				Station No. 1				Station No. 2				Station No. 3							

[How to assign I/O Nos.]

Do not assign I/O Nos. immediately. At first, sort connected remote I/O units in accordance with the steps 3) and 4) above. (Refer to the attachment at the end of this manual.)

After that, assign the first X and the first Y to the position in which a master block is connected as shown in 5) above. In this way, the I/O Nos. of the master block can be easily assigned.

[Example of I/O assignment in standard mode]

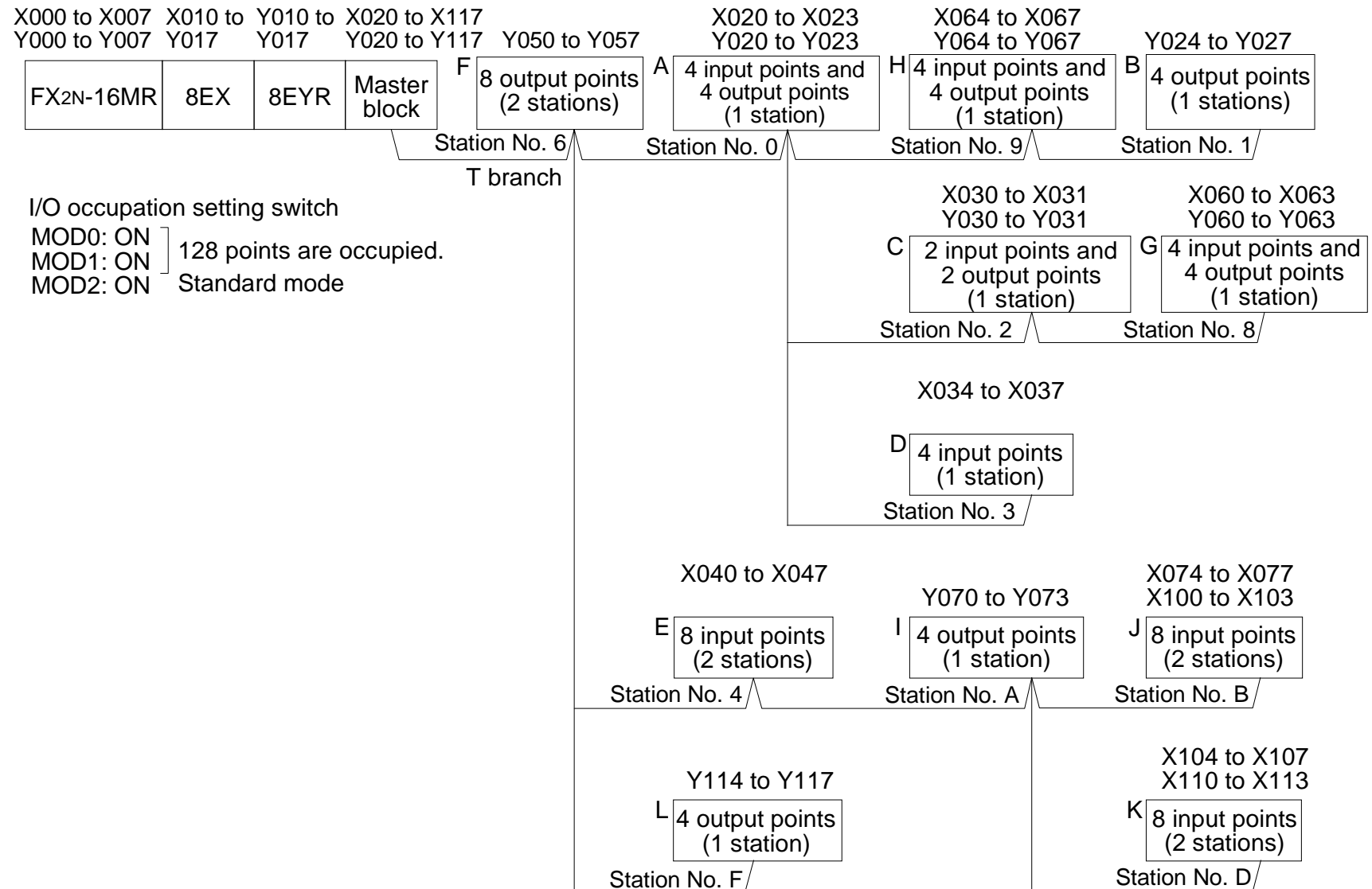

The table below shows I/O assignment to remote I/O units in the system shown on the left.

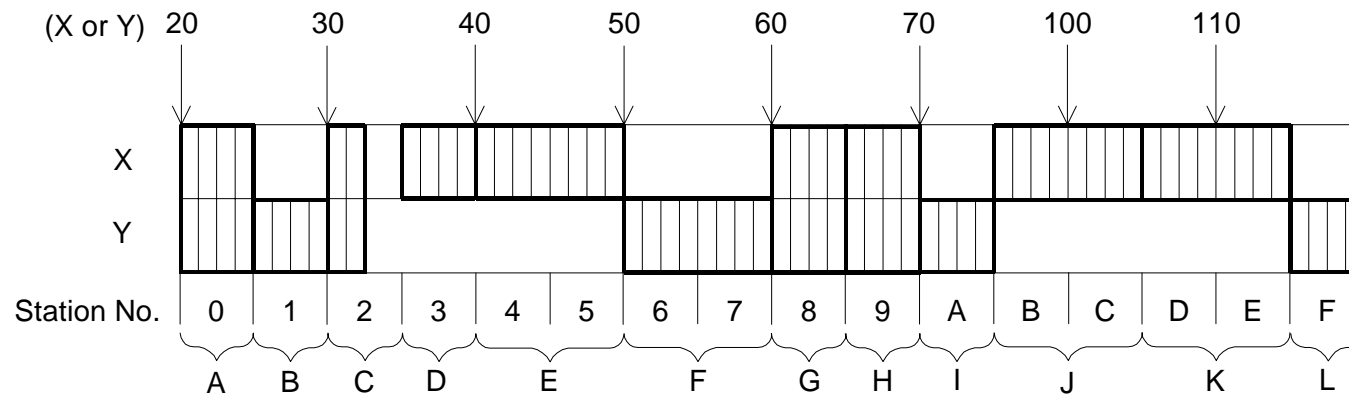

□: A bold line frame shows one remote unit.

Vacant: A vacant No. is occupied by a remote I/O unit.

- Units A, G and H are mixed I/O type units having four input points and four output points. Though one station occupies four points usually, one mixed I/O type unit occupies eight points.
- Unit C is a mixed I/O type unit having two input points and two output points. Two input points and two output points are vacant.
- Other units are remote I/O units dedicated to input or output. In a unit dedicated to input, output points are vacant. In a unit dedicated to output, input points are vacant.
- When there is a vacant station No., for example, when the station No. 8 is vacant (in which no unit is connected) in the system shown on the left, four input points and four output points are vacant. After the unit H (station No. 9), input points from X074 and output points from Y074 are available without regard to existence of the station No. 8.
- When extension units or extension blocks are connected after the master unit in the system on the left, input points from X120 and output points from Y120 are available.
- When "8EX" (extension block dedicated to input) is omitted in the system on the left, input points from X010 are assigned to the input side (X) of a remote I/O unit.

Dedicated I/O type unit mode

When remote I/O units dedicated to input or output (having eight or four input or output points) are used, the dedicated I/O type unit mode can be selected. (When a mixed I/O type remote I/O unit having both input and output points in one unit or a remote I/O unit having 16 points in one unit is used, this mode cannot be selected.)

- 1) When the I/O occupation setting switch MOD2 is set to OFF, I/O No. assignment in the dedicated I/O type unit mode is selected.
- 2) By turning on/off the switches MOD0 and MOD1, determine the number of I/O points occupied by the remote I/O system.
- 3) Assign a station No. and I/O Nos. to each remote I/O unit to be used. (Refer to the assignment table offered as attachment.)

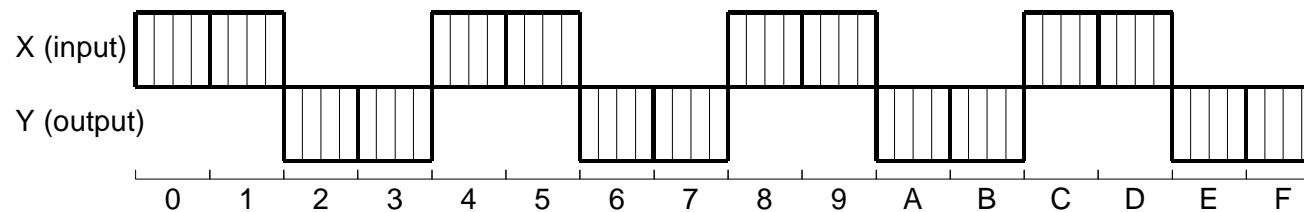

In this mode, each station No. is already assigned to input or output.

Eight points (for two stations) are treated as one unit, and input and output are set alternately from the station Nos. 0 and 1.

- * If a remote unit dedicated to output is connected to a station No. set for input, malfunction will occur. If a remote unit dedicated to input is connected to a station No. set for output, malfunction will occur. (If a mixed I/O type unit or a unit having 16 points is connected, malfunction will occur also.)

4) Assign remote I/O units to be used to the table on the left.

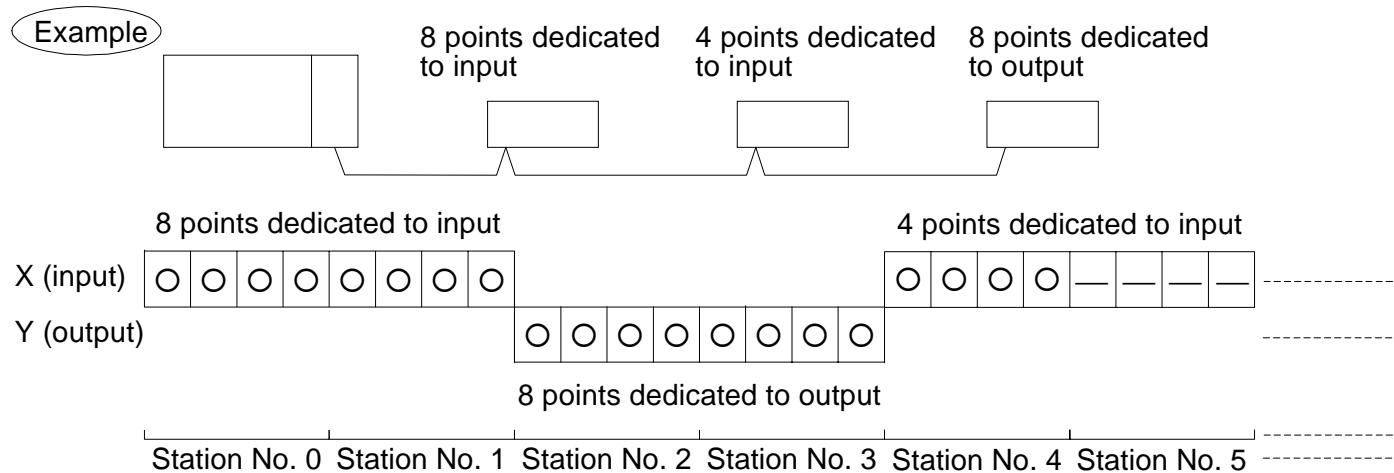

- In the connection sequence, four points dedicated to input are located in a former place. However, four points dedicated to input are set to the station No. 4 because the station Nos. 2 and 3 are set for output.
- The station No. 5 is vacant. However, when one more unit having four points dedicated to input is used, it can be assigned to the station No. 5.
If a unit having eight points dedicated to input is assigned to the station No. 5, latter four points of this unit will malfunction.

- 5) Assign actual I/O Nos.
 From the I/O No. in the position in which the master block FX₂N-16LNK-M is connected, I/O Nos. can be assigned to remote I/O units.

Example When 64 points are occupied

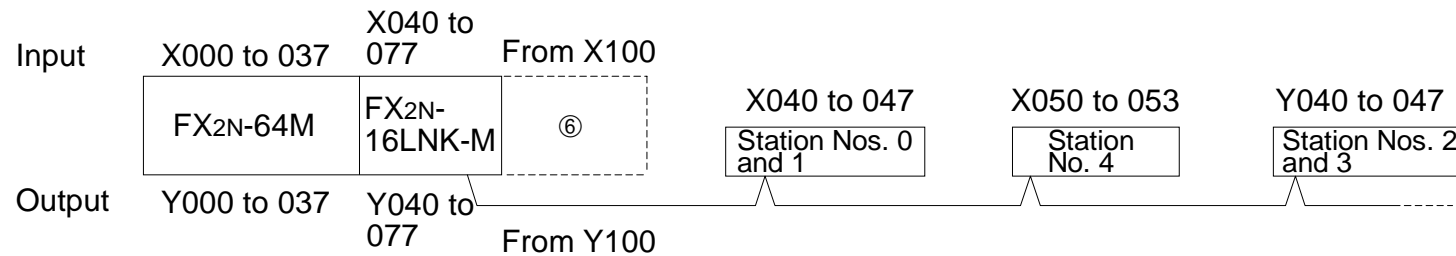

I/O assignment for remote I/O units

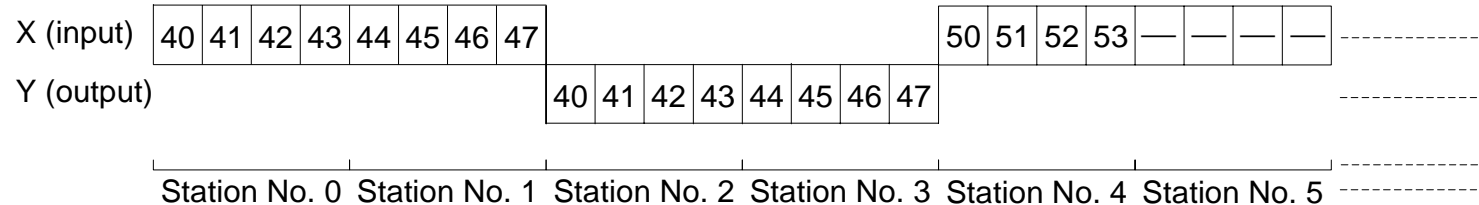

- Assign consecutive numbers to input points. Assign consecutive numbers to output points. In the example above, the input points X054 to X057 are left vacant. Input points from X060 are assigned.
- 6) To extension units/blocks after the master block, I/O Nos. are assigned in the same way as the standard mode. In the example above, input points from X100 and output points from Y100 are assigned.

[Example of I/O assignment in dedicated I/O type unit mode]

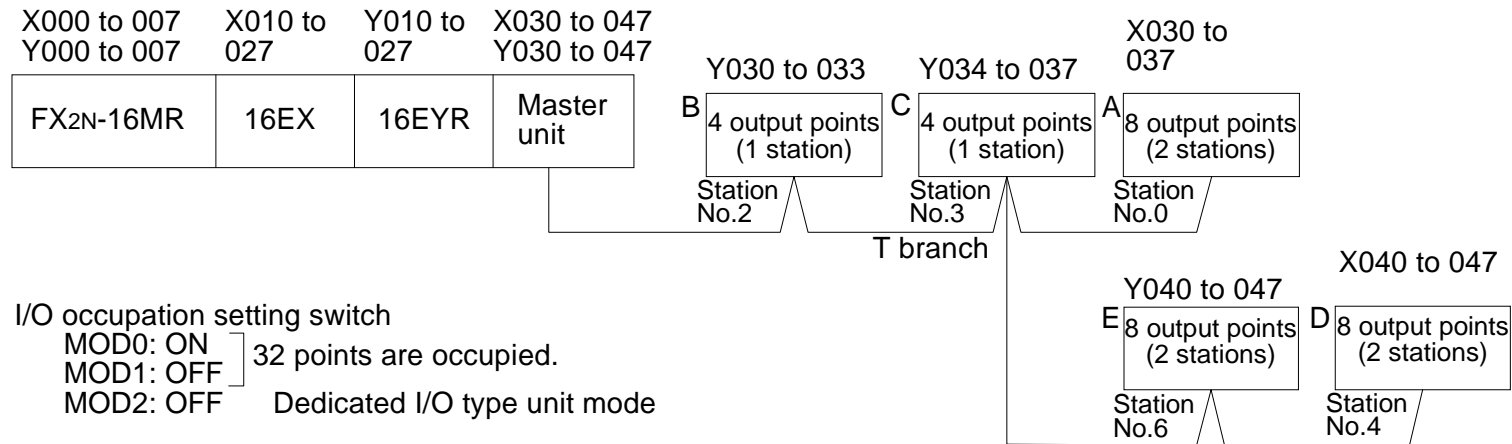

The table below shows I/O assignment for remote I/O units in the system above.

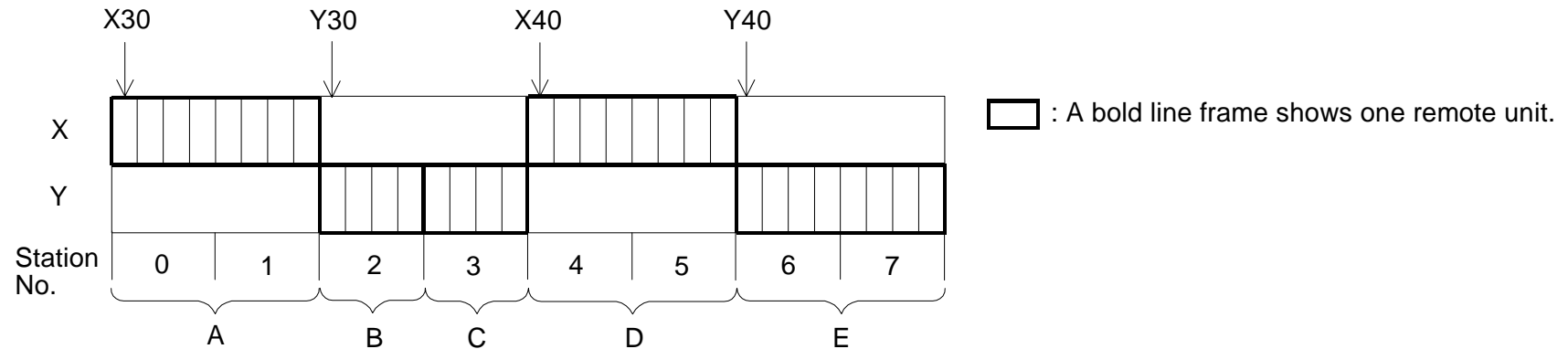

- Units B and C are units having 4 points dedicated to output. If a unit having 8 points dedicated to output is connected as Unit C (station No. 3), latter four points will malfunction.
- Station Nos. for input and station Nos. for output are already determined respectively. Even if the number of occupied I/O points is not more than the specified number, an inappropriate unit cannot be connected. For example, if a unit having eight points dedicated to input is connected to the station No. 6 or 7 which is set for output, it will not function at all.

Programming

- To a remote I/O unit, input points X and output points Y are assigned in the same way as a basic unit, extension units and extension blocks. Assigned I/O points X and Y can be handled by instructions LD, AND and OUT.

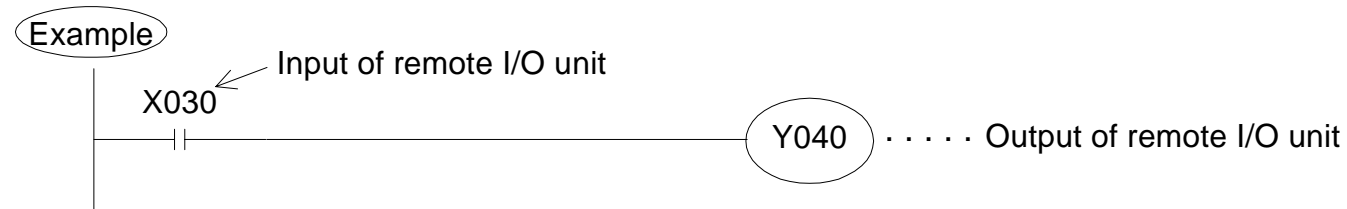

5. Troubleshooting

If a problem has occurred, check the following contents.

Checked position	Status	Action
LEDs on master block	POWER LED is extinguished.	5V DC supplied from PC has come down.
	24V DC LED is extinguished.	Supply 24 VDC power to "+24" and "-24".
	RUN LED is extinguished.	An error has occurred in communication with a remote I/O unit set by on-line station setting switch. Check SHORT, OPEN and PARITY LEDs to detect causes of error.
	SHORT LED is lit.	Check whether DATA and DG are short-circuited.
	OPEN LED is lit.	Check whether signal lines (DATA and DG) are disconnected. Check whether power of remote I/O unit is turned off. Check ERROR STATION LEDs to detect a station with a communication error.
	PARITY LED is lit.	Something is wrong with data received from a remote I/O unit. Noises may be generated.
ERROR STATION LED (0 to F) is lit.	Check a remote I/O unit corresponding to a lighting LED.	
On-line station setting switch on master block	Switch of station No. corresponding to connected remote I/O unit is set to OFF.	Set it to ON.
Station No. of remote I/O unit	One station No. is assigned to two or more remote units.	One station No. can be set to only one remote unit.

[Reference]

The list below shows what can be judged from the LED status in the system configuration shown below. Use this table as a reference of error check.

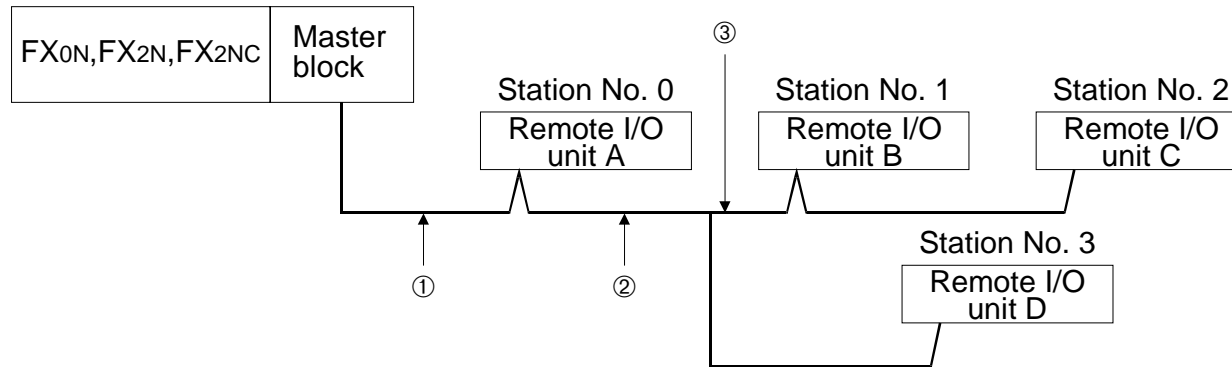

	LED status (●: Lit, ○: Extinguished)					System status
	Master block	Remote I/O unit				
		A	B	C	D	
	POWER ● 24 ● 0 ○ 8 ○ RUN ● 1 ○ 9 ○ SD ● 2 ○ A ○ RD ● 3 ○ B ○ ERR 4 ○ C ○ SHORT ○ 5 ○ D ○ OPEN ○ 6 ○ E ○ PARITY ○ 7 ○ F ○ ERROR STATION	PW ● RUN ● SD ● RD ● ERR ○	PW ● RUN ● SD ● RD ● ERR ○	PW ● RUN ● SD ● RD ● ERR ○	PW ● RUN ● SD ● RD ● ERR ○	Normal
24V LED is extinguished.	POWER ● 24 ○ 0 ● 8 ○ RUN ○ 1 ● 9 ○ SD ● 2 ● A ○ RD ○ 3 ● B ○ ERR 4 ○ C ○ SHORT ○ 5 ○ D ○ OPEN ● 6 ○ E ○ PARITY ○ 7 ○ F ○ ERROR STATION	PW ● RUN ○ SD ○ RD ○ ERR ○	PW ● RUN ○ SD ○ RD ○ ERR ○	PW ● RUN ○ SD ○ RD ○ ERR ○	PW ● RUN ○ SD ○ RD ○ ERR ○	Power is not supplied to +24 and -24 (Or supplied power is insufficient.).
SHORT LED is lit.	POWER ● 24 ● 0 ● 8 ○ RUN ○ 1 ● 9 ○ SD ● 2 ● A ○ RD ● 3 ● B ○ ERR 4 ○ C ○ SHORT ● 5 ○ D ○ OPEN ○ 6 ○ E ○ PARITY ● 7 ○ F ○ ERROR STATION	PW ● RUN ○ SD ○ RD ● ERR ○	PW ● RUN ○ SD ○ RD ● ERR ○	PW ● RUN ○ SD ○ RD ● ERR ○	PW ● RUN ○ SD ○ RD ● ERR ○	DATE and DG are short-circuited. Or DATA and DG may be connected reversely.

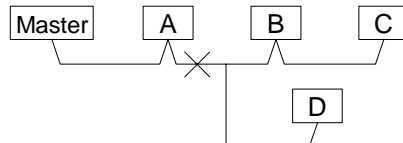
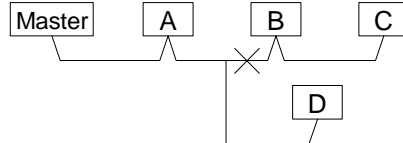
	LED status (●: Lit, ○: Extinguished)					System status
	Master block	Remote I/O unit				
		A	B	C	D	
OPEN LED is lit.	POWER ● 24 ● 0 ● 8 ○ RUN ○ 1 ● 9 ○ SD ● 2 ● A ○ RD ○ 3 ● B ○ ERR 4 ○ C ○ SHORT ○ 5 ○ D ○ OPEN ● 6 ○ E ○ PARITY ○ 7 ○ F ○ ERROR STATION	PW ○ RUN ○ SD ○ RD ○ ERR ○	PW ○ RUN ○ SD ○ RD ○ ERR ○	PW ○ RUN ○ SD ○ RD ○ ERR ○	PW ○ RUN ○ SD ○ RD ○ ERR ○	Wiring may be disconnected, a remote I/O unit may be defective, or power may be turned off. PW LEDs on remote I/O units are extinguished, so power is turned off or remote I/O units are defective.
	POWER ● 24 ● 0 ○ 8 ○ RUN ○ 1 ● 9 ○ SD ● 2 ● A ○ RD ● 3 ● B ○ ERR 4 ○ C ○ SHORT ○ 5 ○ D ○ OPEN ● 6 ○ E ○ PARITY ○ 7 ○ F ○ ERROR STATION	PW ● RUN ● SD ● RD ● ERR ○	PW ● RUN ○ SD ○ RD ○ ERR ○	PW ● RUN ○ SD ○ RD ○ ERR ○	PW ● RUN ○ SD ○ RD ○ ERR ○	Wiring may be disconnected, a remote I/O unit may be defective, or power may be turned off. PW LEDs on remote I/O units are lit, so wiring is disconnected in position ②. 
	POWER ● 24 ● 0 ○ 8 ○ RUN ○ 1 ● 9 ○ SD ● 2 ● A ○ RD ● 3 ○ B ○ ERR 4 ○ C ○ SHORT ○ 5 ○ D ○ OPEN ● 6 ○ E ○ PARITY ○ 7 ○ F ○ ERROR STATION	PW ● RUN ● SD ● RD ● ERR ○	PW ● RUN ○ SD ○ RD ○ ERR ○	PW ● RUN ○ SD ○ RD ○ ERR ○	PW ● RUN ● SD ● RD ● ERR ○	Wiring may be disconnected, a remote I/O unit may be defective, or power may be turned off. PW LEDs on remote I/O units are lit, so wiring is disconnected in position ③. 

	LED status (●: Lit, ○: Extinguished)					System status
	Master block	Remote I/O unit				
		A	B	C	D	
OPEN LED is lit.	POWER ● 24 ● 0 ● 8 ○ RUN ○ 1 ● 9 ○ SD ● 2 ● A ○ RD ● 3 ● B ○ ERR 4 ○ C ○ SHORT ○ 5 ○ D ○ OPEN ● 6 ○ E ○ PARITY ○ 7 ○ F ○ ERROR STATION	PW ● RUN ○ SD ○ RD ○ ERR ○	PW ● RUN ○ SD ○ RD ○ ERR ○	PW ● RUN ○ SD ○ RD ○ ERR ○	PW ● RUN ○ SD ○ RD ○ ERR ○	Wiring may be disconnected, a remote I/O unit may be defective, or power may be turned off. PW LEDs on remote I/O units are lit, so wiring is disconnected in position ①.
	POWER ● 24 ● 0 ○ 8 ○ RUN ○ 1 ● 9 ○ SD ● 2 ○ A ○ RD ● 3 ○ B ○ ERR 4 ○ C ○ SHORT ○ 5 ○ D ○ OPEN ● 6 ○ E ○ PARITY ○ 7 ○ F ○ ERROR STATION	PW ● RUN ● SD ● RD ● ERR ○	PW ○ RUN ○ SD ○ RD ○ ERR ○	PW ● RUN ● SD ● RD ● ERR ○	PW ● RUN ● SD ● RD ● ERR ○	Wiring may be disconnected, a remote I/O unit may be defective, or power may be turned off. PW LED on remote I/O unit B is extinguished, so power is turned off or remote I/O unit B is defective.
PARITY LED is lit.	POWER ● 24 ● 0 ○ 8 ○ RUN ○ 1 ○ 9 ○ SD ● 2 ● A ○ RD ● 3 ○ B ○ ERR 4 ○ C ○ SHORT ○ 5 ○ D ○ OPEN ○ 6 ○ E ○ PARITY ● 7 ○ F ○ ERROR STATION	PW ● RUN ● SD ● RD ● ERR ○	PW ● RUN ● SD ● RD ● ERR ○	PW ● RUN ○ SD ○ RD ● ERR ●	PW ● RUN ● SD ● RD ● ERR ○	Remote I/O unit C is defective. ERR LED on remote I/O unit C is lit, so this unit cannot receive correctly data from master block. (It may be caused by noises.)

Memo

6. Remote I/O Unit

6.1 Model name structure

For the detailed specifications of a remote I/O unit, refer to the manual of the MELSEC-I/O LINK REMOTE I/O SYSTEM MASTER UNIT (page 1-2).

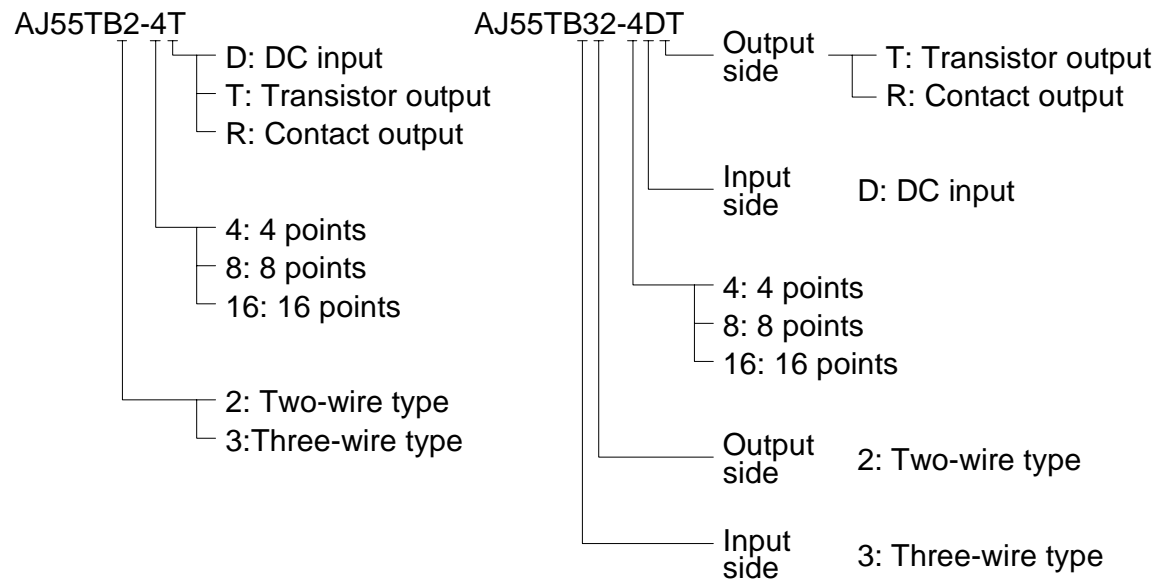

One remote I/O unit occupies four points.

However, one mixed I/O type remote I/O unit having eight points occupies eight points.

6.2 Outside dimensions

The figure and the table below show the outside dimensions of a remote I/O unit.

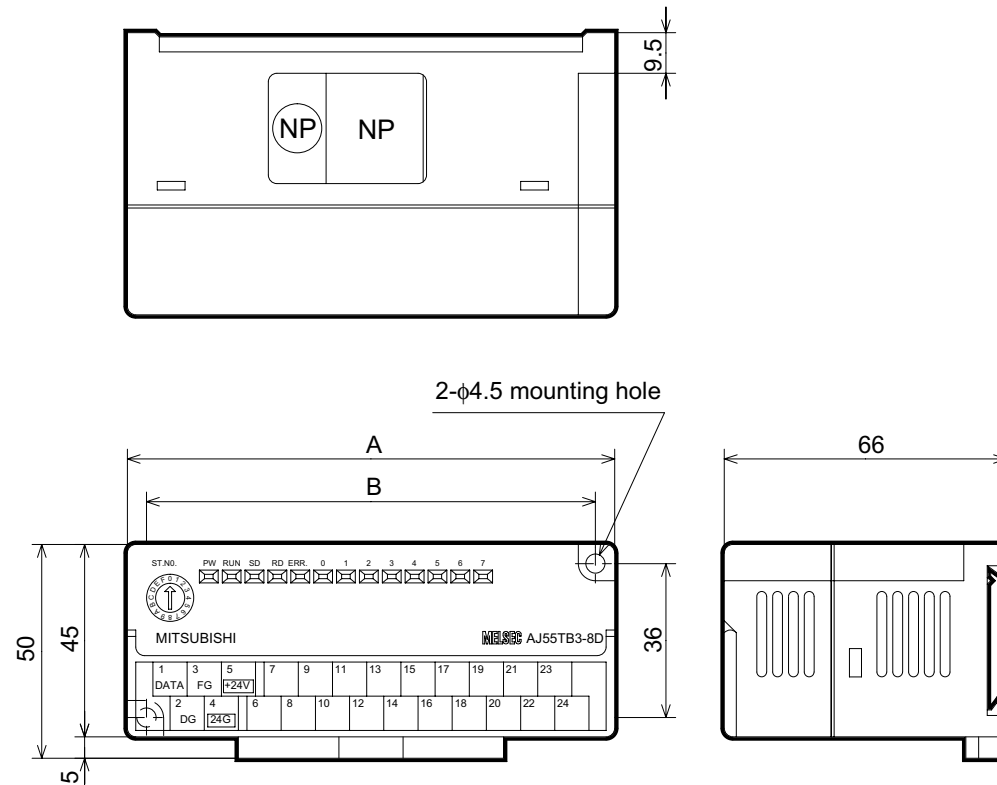

Model name	Dimensions	
	A	B
AJ55TB□□-4□□	82	73
AJ55TB□□-8□□	114	105
AJ55TB□□-16□□	177	168

Appendix

[Number of I/O points and stations]

The figures below show the number of occupied I/O points and stations of each remote I/O unit.
For details of use, refer to the user manual of A Series MELSEC-I/O LINK REMOTE I/O SYSTEM MASTER UNIT (detailed volume).

"□" shows a model name expressing the input method, the output method and the connection method.

- Unit having 4 points dedicated to input
AJ55TB□-4□
Number of occupied stations: 1

	0	1	2	3
X				
Y	—	—	—	—

- Unit having 8 points dedicated to input
AJ55TB□-8□
Number of occupied stations: 2

	0	1	2	3	4	5	6	7
X								
Y	—	—	—	—	—	—	—	—

- Unit having 16 points dedicated to input
AJ55TB□-16□
Number of occupied stations: 4

	0	1	2	3	4	5	6	7	0	1	2	3	4	5	6	7
X																
Y	—	—	—	—	—	—	—	—	—	—	—	—	—	—	—	—

- Unit having 4 points dedicated to output
AJ55TB□-4□
Number of occupied stations: 1

	0	1	2	3
X	—	—	—	—
Y				

- Unit having 8 points dedicated to output
AJ55TB□-8□
Number of occupied stations: 2

	0	1	2	3	4	5	6	7
X	—	—	—	—	—	—	—	—
Y								

- Unit having 16 points dedicated to output
AJ55TB□-16□
Number of occupied stations: 4

	0	1	2	3	4	5	6	7	0	1	2	3	4	5	6	7
X	—	—	—	—	—	—	—	—	—	—	—	—	—	—	—	—
Y																

- Unit having 4 points for input and output (2 for input and 2 for output)
 AJ55TB□-4□
 Number of occupied stations: 1

	0	1	2	3
X				
Y				

- Unit having 8 points for input and output (4 for input and 4 for output)
 AJ55TB□-8□
 Number of occupied stations: 1

	0	1	2	3
X				
Y				

- Unit having 16 points for input and output (8 for input and 8 for output)
 AJ55TB□-16□
 Number of occupied stations: 2

	0	1	2	3	4	5	6	7
X								
Y								

[I/O assignment table for remote I/O units]

Use this table to assign I/O Nos. to remote I/O units. (It is recommended to copy it in a larger size.)

Standard mode

X																
Y																
Station No.	0				1				2				3			
X																
Y																
Station No.	4				5				6				7			
X																
Y																
Station No.	8				9				A				B			
X																
Y																
Station No.	C				D				E				F			

32 points are occupied.

64 points are occupied.

96 points are occupied.

128 points are occupied.

Dedicated I/O type unit mode

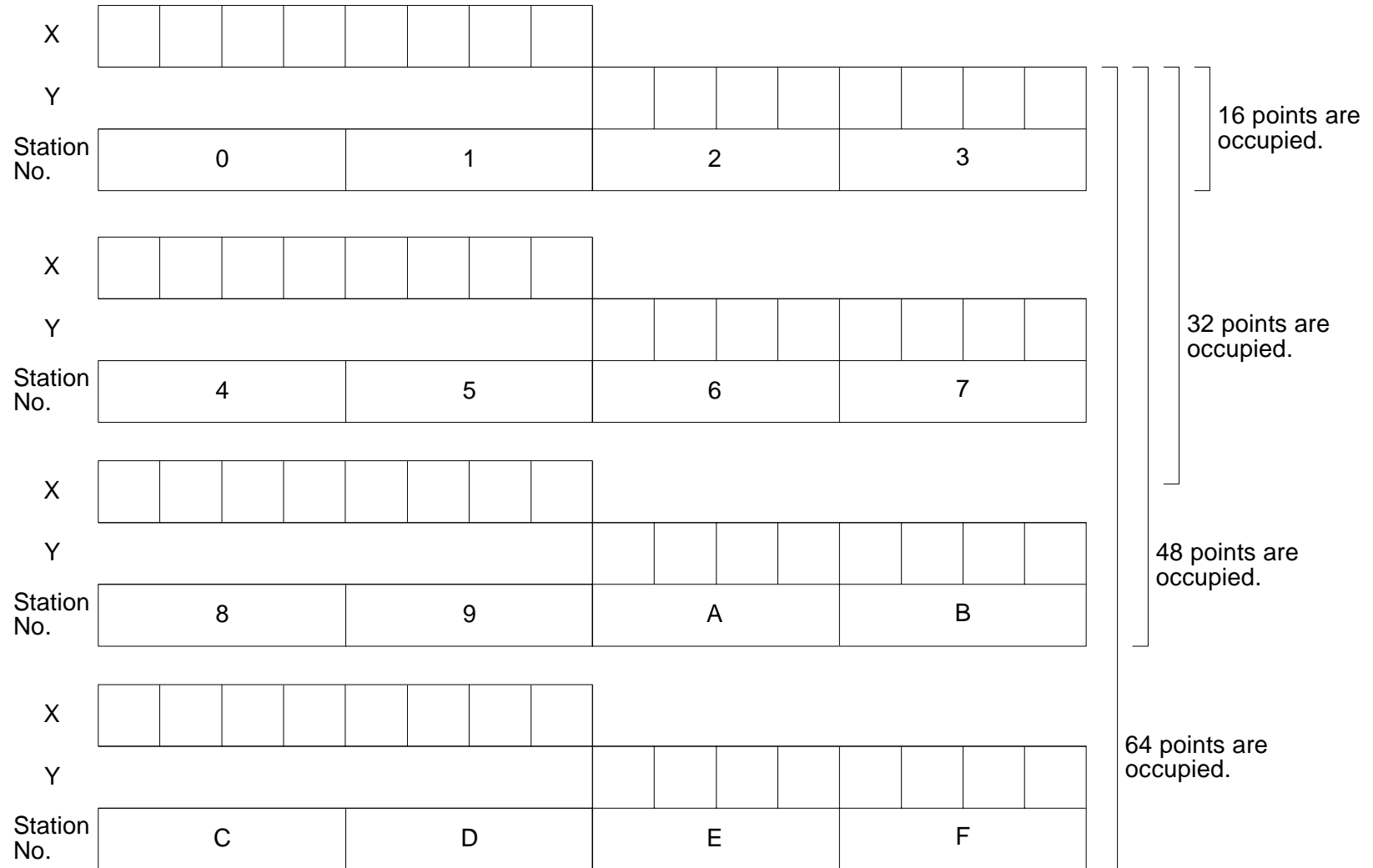

Memo

Under no circumstances will MITSUBISHI ELECTRIC be liable responsible for any consequential damage that may arise as a result of the installation or use of this equipment.

All examples and diagrams shown in this manual are intended only as an aid to understanding the text, not to guarantee operation. MITSUBISHI ELECTRIC will accept no responsibility for actual use of the product based on these illustrative examples.

Owing to the very great variety in possible application of this equipment, you must satisfy yourself as to its suitability for your specific application.

USER'S MANUAL

FX₂N-16LNK-M MELSEC-I/O LINK
REMOTE I/O SYSTEM MASTER BLOCK



HEAD OFFICE: MITSUBISHI DENKI BLDG MARUNOUCHI TOKYO 100-8310 TELEX: J24532 CABLE MELCO TOKYO
HIMEJI WORKS: 840, CHIYODA CHO, HIMEJI, JAPAN

JY992D73701B
(MEE 9810)

Effective OCT.1998
Specifications are subject
to change without notice.