

SIMATIC NET

CP 242-8 AS-Interface Master / PROFIBUS-DP Slave

Manual

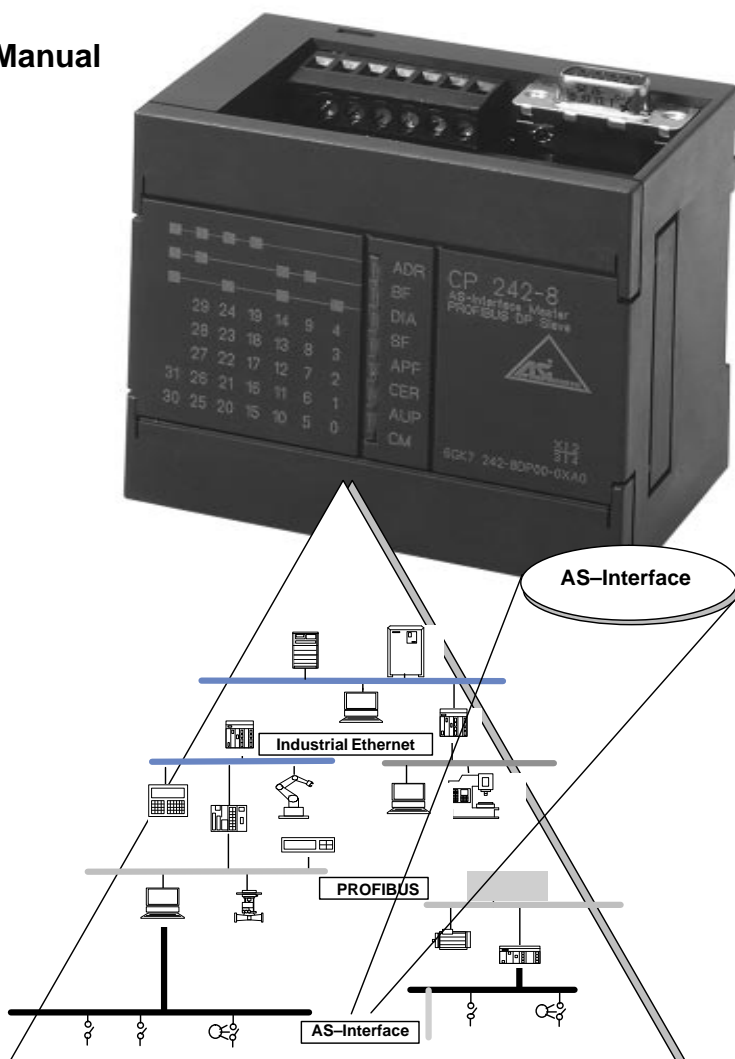

C79000-G8976-C109

Release 01

Preface, Contents

Technical Description and
Installation Instructions **1**

Interface to the User Program in
the S7-200 **2**

CP 242-8 as AS-Interface Master **3**

Interface to PROFIBUS DP
(CP 242-8 as DP Slave) **4**

Dealing with Problems /
Error Displays **5**

Appendix

AS-Interface Protocol Implemen-
tation Conformance Statements **A**

Structure of the PROFIBUS
Parameter Assignment and
Configuration Frame **B**

References **C**

Note on the CE Label **D**

Glossary, Index

Safety Guidelines

This manual contains notices which you should observe to ensure your own personal safety, as well as to protect the product and connected equipment. These notices are highlighted in the manual by a warning triangle and are marked as follows according to the level of danger:



Danger

indicates that death, severe personal injury or substantial property damage **will** result if proper precautions are not taken.



Warning

indicates that death, severe personal injury or substantial property damage **can**, result if proper precautions are not taken.



Caution

indicates that minor personal injury or property damage can result if proper precautions are not taken.

Note

draws your attention to particularly important information on the product, handling the product, or to a particular part of the documentation.

Qualified Personnel

Only **qualified personnel** should be allowed to install and work on this equipment. Qualified persons are defined as persons who are authorized to commission, to ground, and to tag circuits, equipment, and systems in accordance with established safety practices and standards.

Correct Usage

Note the following:



Warning

This device and its components may only be used for the applications described in the catalog or the technical description, and only in connection with devices or components from other manufacturers which have been approved or recommended by Siemens.

This product can only function correctly and safely if it is transported, stored, set up, and installed correctly, and operated and maintained as recommended.

Trademarks

SIMATIC® and SIMATIC NET® are registered trademarks of SIEMENS AG.

Third parties using for their own purposes any other names in this document which refer to trademarks might infringe upon the rights of the trademark owners.

Copyright Siemens AG 1997 All rights reserved

The reproduction, transmission or use of this document or its contents is not permitted without express written authority. Offenders will be liable for damages. All rights, including rights created by patent grant or registration of a utility model or design, are reserved.

Siemens AG
Automation Group
Industrial Automation Systems
Postfach 4848, D-90327 Nuremberg

Disclaimer of Liability

We have checked the contents of this manual for agreement with the hardware and software described. Since deviations cannot be precluded entirely, we cannot guarantee full agreement. However, the data in this manual are reviewed regularly and any necessary corrections included in subsequent editions. Suggestions for improvement are welcomed.

© Siemens AG 1997
Subject to change.

Preface

Purpose of the Manual

This manual supports you when using the **CP 242-8** module. It explains how an S7-200 CPU can address AS-i actuators and AS-i sensors via this module. The manual also explains how to access an S7-200 station as a PROFIBUS DP slave via the CP 242-8.

We recommend the following procedure when...

...you want an overall picture of the AS-Interface:

- First read the 'AS-Interface Introduction and Basic Information' manual (part of this documentation package). This contains general information about the **AS-Interface** abbreviated to **AS-i** in the following chapters.

...You want to set up an AS-i system and include the CP 242-8 module in it:

- You will find the information you require about connecting and operating the CP 242-8 module in Chapter 3.

...You want to know how to operate the CP 242-8 from the point of view of the PROFIBUS DP master:

- Read Chapter 4 in this manual.

Requirements

To understand this manual, you require the following:

- A working knowledge of PROFIBUS DP
- You should be familiar with the 'AS-Interface Introduction and Basic Information' manual (supplied with this documentation package).

Diskette with Sample Program and Type/GSD File

The diskette accompanying this manual (S7-200 PROGR) contains sample programs that will support and help you when programming the CP 242-8. These sample programs were written with STEP 7 Micro/WIN and can be run on an S7-200 CPU.

The diskette also contains the type and DDB file you require for configuring the CP 242-8 with your DP master. (See Section 4.4, Configuring the CP 242-8 on the DP Master / Content of the Type File and the DDB file.)

Further Support – Who to Contact

If you have technical questions about using the product described here, please contact your local Siemens representative.

The addresses are listed:

- in our catalog IK 10
- on the Internet (<http://www.ad.siemens.de>)

Common Questions

Our customer support on the Internet provides useful information and answers to frequently asked questions (FAQ). Under FAQ, you will find information about our entire range of products.

The address of the AUT homepage in the World Wide Web of the Internet is as follows:

<http://www.ad.siemens.de/net>

Further Support – Hotline

- Our hotline is also available to deal with problems:
- Telephone: 0911 – 895 – 7000
(from abroad +49 – 911 – 895 – 7000)
- Telefax: 0911 – 895 – 7001
(from abroad +49 – 911 – 895 – 7001)
- E-Mail: simatic.support@nbgm.siemens.de
- Mailbox (BBS, analog/ISDN, 8N1):
0911 – 895 – 7100
(from abroad +49 – 911 – 895 – 7100)



Contents

1	Technical Description and Installation Instructions	1-1
1.1	General	1-2
1.2	Application of the Module	1-4
1.3	Technical Specifications of the Module	1-6
1.4	Installing the Module	1-7
1.5	Front Panel – Access to all Functions	1-8
1.6	Connection Elements	1-9
1.7	Display and Control Elements	1-11
1.7.1	Status Display	1-12
1.7.2	Slave Display for AS-i Slaves	1-14
1.7.3	Displaying and Setting the PROFIBUS Address	1-16
1.8	Configuring the AS-Interface with the SET Button	1-18
2	Interface to the User Program in the S7-200 CPU	2-1
2.1	CP 242-8 Connects the S7-200 CPU with PROFIBUS DP and AS-Interface	2-2
2.2	Addressing the CP 242-8 in the S7-200 CPU	2-4
2.3	Meaning of the Data in the Digital Module	2-7
2.3.1	Identification Register in the Digital Module	2-8
2.3.2	Error Register in the Digital Module	2-9
2.3.3	Status Byte (Input Register 8DI)	2-11
2.3.4	Control Byte (Output Register 8DO)	2-13
2.4	Meaning of the Data in the Analog Module	2-14
2.4.1	Identification Register in the Analog Module	2-15
2.4.2	Error Register in the Analog Module	2-16
2.5	Access to the Analog Input and Output Words	2-17
2.5.1	Analog Input Area	2-18
2.5.2	Analog Output Area	2-20
3	CP 242-8 as AS-Interface Master	3-1
3.1	About this Chapter	3-2
3.2	Addressing the AS-i Slaves with the User Program	3-3
3.3	Access to the AS-i User Data	3-6
3.4	Signaling Errors and Diagnostic Information	3-7
3.5	Command interface of the CP 242-8	3-9
3.6	Description of the AS-i Commands	3-13
3.6.1	Set_Permanent_Parameter	3-18

3.6.2	Get_Permanent_Parameter	3-19
3.6.3	Write_Parameter	3-20
3.6.4	Read_Parameter	3-21
3.6.5	Store_Actual_Parameters	3-22
3.6.6	Set_Permanent_Configuration	3-23
3.6.7	Get_Permanent_Configuration	3-24
3.6.8	Store_Actual_Configuration	3-25
3.6.9	Read_Actual_Configuration	3-26
3.6.10	Set_LPS	3-27
3.6.11	Set_Offline_Mode	3-28
3.6.12	Select Autoprogramming	3-29
3.6.13	Set_Operation_Mode	3-30
3.6.14	Change_Slave_Address	3-31
3.6.15	Read Slave Status	3-32
3.6.16	Read Lists and Flags (Get_LPS, Get_LAS, Get_LDS, Get_Flags)	3-33
3.6.17	Read Total Configuration	3-35
3.6.18	Configure Total System	3-37
3.6.19	Write Parameter List	3-40
3.6.20	Read Parameter Echo List	3-41
3.6.21	Read Version ID	3-42
3.6.22	Read and Delete Slave Status	3-43
3.6.23	Read Slave ID	3-44
3.6.24	Read Slave I/O	3-45
3.6.25	Read Data and Delta List	3-46
4	The CP 242-8 as PROFIBUS DP Slave	4-1
4.1	Transferring User Data Between the DP Master and CP 242-8	4-2
4.2	Controlling Access with the DP Data Area	4-4
4.2.1	Byte-Consistent Data Transfer	4-5
4.2.2	Block-Consistent Data Transfer	4-7
4.3	DP Status Information	4-11
4.4	Configuring the CP 242-8 in the DP Master/Content of the Type File and the DDB File	4-13
4.5	Transmission Rate on PROFIBUS	4-16
4.6	PROFIBUS DP Control Commands	4-17
4.7	DP Slave Diagnostics	4-18
4.7.1	Station Status 1 to 3	4-19
4.7.2	PROFIBUS Address of the DP Master and Vendor ID	4-21
4.7.3	Structure of the Device-Related Diagnostic Information	4-21
5	Dealing with Problems / Error Displays	5-1
5.1	Replacing a Defective AS-i Slave/Automatic Address Programming	5-2
5.2	Error Indicators on the CP 242-8/ Dealing with Errors	5-3

Appendix

A	AS-Interface Protocol Implementation Conformance Statement (PICS)	A-1
B	Structure of the PROFIBUS DP Parameter Assignment and Configuration Frame	B-1
C	References	C-1
D	Notes on the CE Label	D-1
	Glossary	
	Index	



Technical Description and Installation Instructions

1

1.1	General	1-2
1.2	Application of the Module	1-4
1.3	Technical Specifications of the Module	1-6
1.4	Installing the Module	1-7
1.5	Front Panel – Access to all Functions	1-8
1.6	Connection Elements	1-9
1.7	Display and Control Elements	1-11
1.7.1	Status Display	1-12
1.7.2	Slave Display for AS-i Slaves	1-14
1.7.3	Displaying and Setting the PROFIBUS Address	1-16
1.8	Configuring the AS-Interface with the SET Button	1-18

1.1 General

This chapter explains the performance, installation and basic functions of the master module CP 242-8.

You will learn the following:

- Which PLC systems can be operated with the CP 242-8 on PROFIBUS DP and AS-Interface
- Which modes are supported by the CP 242-8
- How to install the CP 242-8
- The display and control elements of the CP 242-8
- How to configure the CP 242-8 by pushbutton
- How to set the PROFIBUS address on the CP 242-8



Caution

When handling and installing the CP 242-8 module, make sure that you adhere to the ESD guidelines.

The CP 242-8 must only be connected when the AS-i power supply unit is turned off.



Caution

Noise immunity/grounding

To ensure the noise immunity of the CP 242-8, both the CP 242-8 and the AS-i power supply unit must be grounded correctly.



Caution

The AS-i power supply unit used must provide a low voltage, safely isolated from the network. This safe isolation can be implemented according to the following requirements:

- VDE 0100 Part 410 = HD 38444 = IEC 364441
(as functional extra-low voltage with safe isolation) or
 - VDE 0805 = EN60950 = IEC 950
(as safety extra-low voltage SELV) or
 - VDE 0106 Part 101
-



Caution

The external 24 V power supply must be safely isolated.

Note

The CP 242-8 can be configured, installed and started up separate from the PROFIBUS installation.

1.2 Application of the Module

DP Slave and AS-Interface Master

The CP 242-8 module can be operated in the S7 – 200 programmable logic controller. It allows the simultaneous attachment of an S7 – 200 to PROFIBUS DP (as a DP slave) and to the AS-Interface (as AS-Interface master). Both network attachments can be used independently of each other.

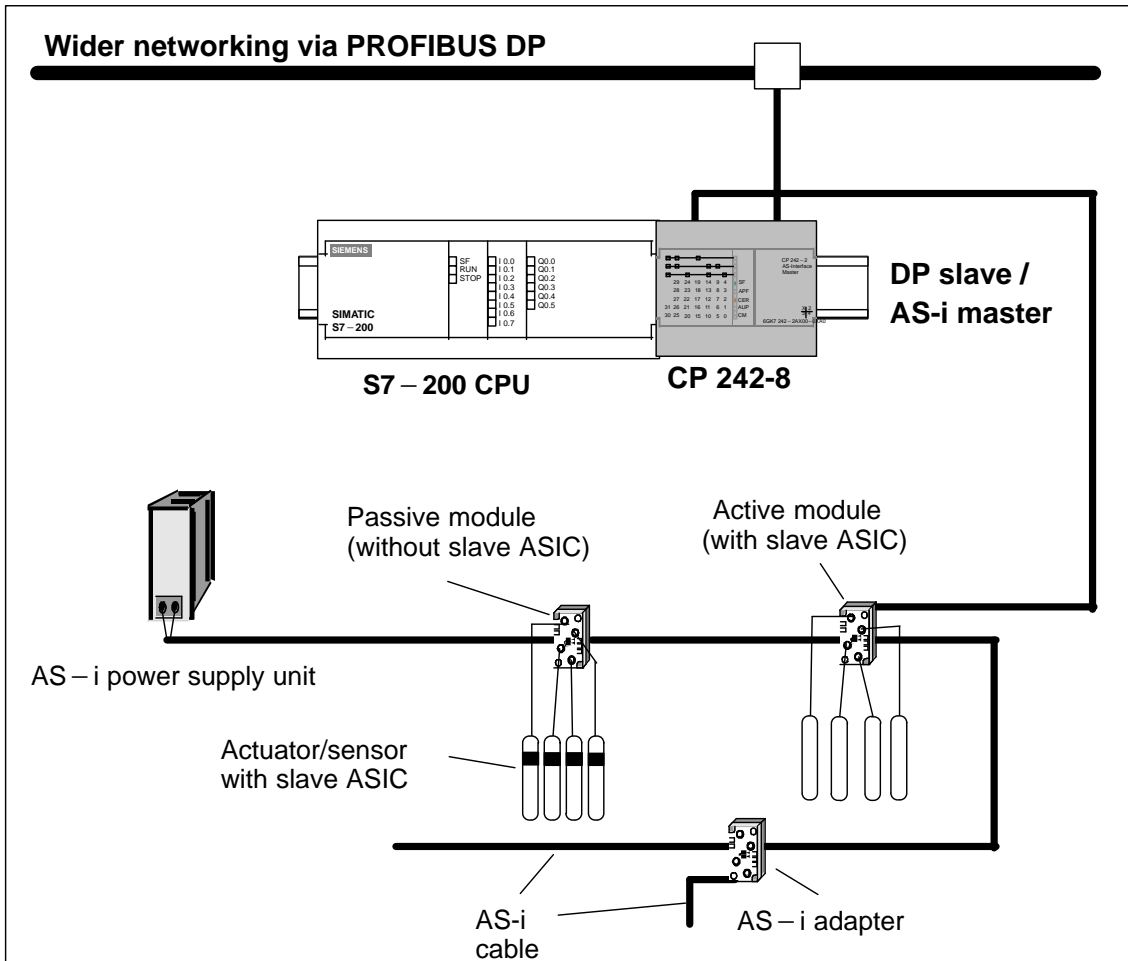

Figure 1-1 Example of a System Setup with the CP 242-8

System Integration and Structure

Refer to the accompanying product information bulletin to find out the CPUs with which the CP 242-8 can be operated.

From the point of view of the S7 – 200 CPU, the CP 242-8 is considered as two expansion modules (one 8DI/8DO digital module and one 8AI/8AO analog module).

In terms of installation, the CP 242-8 has the same technology as a standard expansion module for an S7 – 200 station.

Power Supply

The CP 242-8 requires an external 24 V power supply for operation.

Components of the Product

The product CP 242-8 includes the following components:

- CP 242-8
- Bus connector
- Product Information for the CP 242-8

1.3 Technical Specifications of the Module

The CP 242-8 module has the following technical specifications:

Table 1-1

Feature	Explanation/Values
AS-i cycle time	5 ms with 31 slaves
Configuration of the AS-Interface	By a button on the front panel
Supported AS-i master profiles	M1
Connection of the AS-i cable	Via a 7-pin terminal block Permitted current loading from pin 1 to pin 3 or pin 2 to pin 4, maximum 3 A
Connection to PROFIBUS	Via 9-pin sub D female connector
PROFIBUS address setting	– Address range 1 to 126 – Set with SET and DISPLAY buttons
Permitted loading 5V DC at PROFIBUS connector	max. 90 mA
Data rates supported (transmission rate) on PROFIBUS	9.6 Kbps; 19.2 Kbps; 45.45 Kbps; 93.75 Kbps; 187.5 Kbps; 500 Kbps; 1.5 Mbps; 3 Mbps; 6 Mbps; 12 Mbps
Connection to an external 24 V power supply	Via terminal block (7-pin)
Address range	One digital module with 8DI/8DO and one analog module with 8AI/8AO
Power supply from SIMATIC backplane bus	5 V DC
Current consumption from 5V DC	max. 340 mA
External power supply	24 V DC (permitted range 20.4 to 28.8V DC)
Current consumption from 24 V	max. 60 mA
Power supply from the AS-i cable	According to the AS-I specification
Current consumption from the AS-i cable	max. 100 mA
Power consumption	3.7 W
Ambient conditions	
• Operating temperature	Horizontal installation: 0 to 55°C Vertical installation: 0 to 45°C
• Transportation and storage temperature	– 40°C to +70°C
• Relative humidity	max. 95% at +25°C
Construction	
• Type of protection	IP 20
• Module format	S7-200 expansion module
• Dimensions (W x H x D) in mm	90 x 80 x 62
• Weight	approx. 200 g

1.4 Installing the Module

Slots in the S7-200

The CP 242-8 can be used in all slots for expansion modules on the S7-200 programmable controller.

Restrictions

There are, however, restrictions regarding the CPU or power supply used in terms of the following:

- The expandability with more than one expansion module

For data on this topic, refer to /4/;

- The electrical design

The maximum current consumption from the S7 backplane bus must not be exceeded. To calculate the current requirements, use the calculation table in /4/.

1.5 Front Panel – Access to all Functions

Connection, Display and Control Elements

On the front panel, you have access to all the connection, display and control elements of the CP 242-8.

During operation, connection and control elements are protected by a front cover.

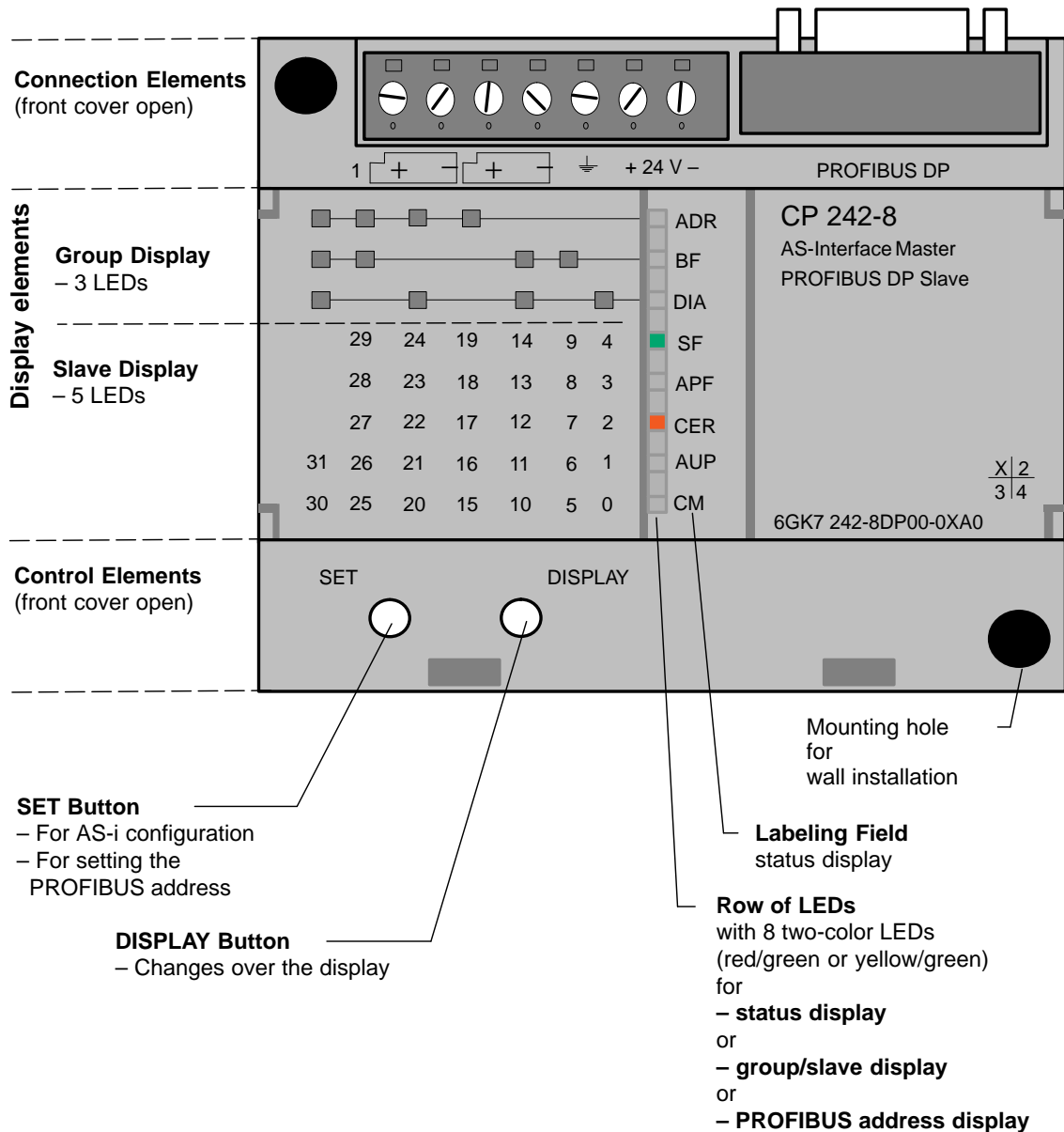

Figure 1-2 Front Panel

Connections, Operator Controls and Interpreting the Displays

For more detailed information, refer to the following sections.

1.6 Connection Elements

Connections

The CP 242-8 has the following connectors:

- Two connectors to the AS-i cable (bridged internally)
- One connector for the external 24 V supply
- One connection for functional earth
- One connector to PROFIBUS (9-pin sub D female connector)

The connectors are located below the upper cover of the front panel of the CP 242-8.

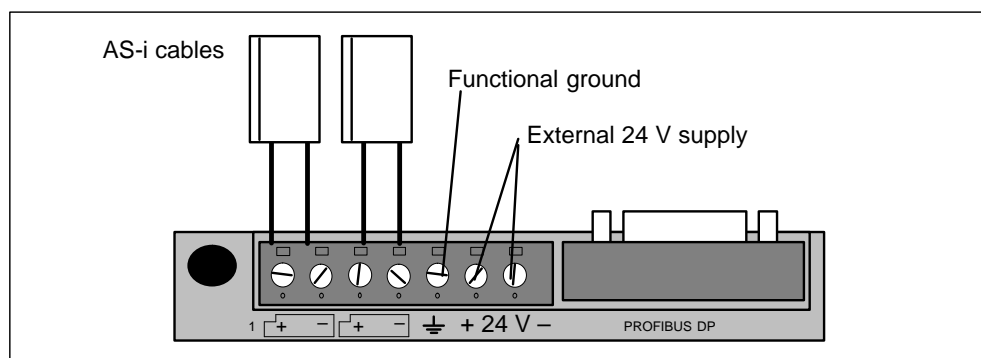

Figure 1-3 Connection of the AS-i Cable

Connections to the AS-i cable

The CP 242-8 has two connectors for AS-i cables that are bridged internally in the CP 242-8.

This allows the CP 242-8 to be looped into the AS-i cable.



Caution

The permitted current loading of the AS-i connection contacts is 3 A. If this value is exceeded on the AS-i cable, the CP 242-8 must not be looped into the AS-i cable but must be connected with a tap line (only one pair of connectors of the CP 242-8 is used).

External Power Supply

The CP 242-8 requires an external 24 V power supply (the permitted voltage range is 20.4 to 28.8V DC). The current required from the 24 V supply is 60 mA.

With the AC and relay variants of the S7-200 CPUs, the sensor/transmitter supply provided by the CPU can be used (see /4/).

Note

Functional ground (**terminal** )

The CP 242-8 has a connector for functional ground. This connector should be connected to the PE conductor with as little resistance as possible.

Connection to PROFIBUS DP

Connection to PROFIBUS DP is via a 9-pin sub D female connector.



Warning

When laying and installing the PROFIBUS DP cable and the bus connector, follow the instructions in /5/.

To attach to PROFIBUS DP, it is advisable to use bus connector 6ES7 972-0BA40-0XA0.

1.7 Display and Control Elements

Meaning of the ADR, BF and DIA LEDs

The front panel of the CP 242-8 has a row with 8 LEDs (see Figure 1-2). All the LEDs are 2-color (red/green or yellow/green). The upper three LEDs (ADR, BF and DIA) make up the group display. They indicate the display status.

Changing the Display Status – DISPLAY Button

The following figure shows the possible display statuses of the group display.

You can change between the status display, slave display and PROFIBUS address display with the **DISPLAY** button. Each time you press the button, you change to the next display status finally returning to the initial status.

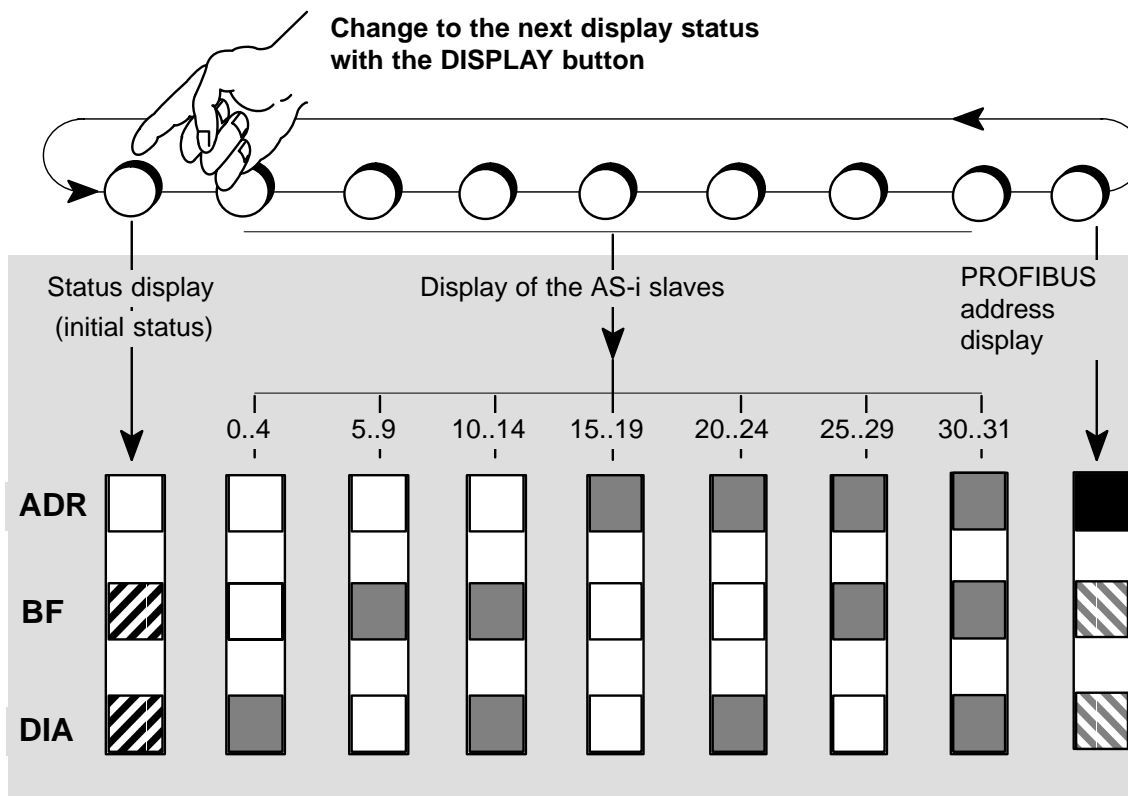

Key: red red/yellow or off green green or off off

1.7.1 Status Display

Interpreting the Status Display

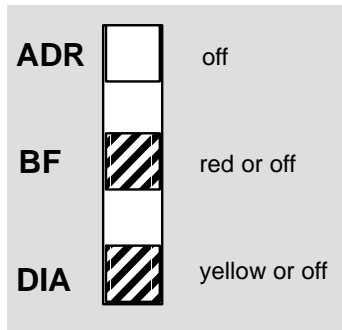

The status display is easily recognized because no group LED is lit green. The "ADR" LED must also not be lit red.

The status display is the default standard display in the initial state of the CP 242-8.

The lower 7 LEDs indicate the status of the CP 242-8; the label to the right of the LEDs then applies.

The bottom 5 LEDs indicate errors/states on the AS-Interface. The BF and DIA LEDs indicate errors or diagnostic messages on PROFIBUS DP.

Meaning of the 7 Lower LEDs

When the status display is active, the LEDs have the following significance:

Table 1-2

LED (color)	Status	Meaning
BF (red)	Bus Failure	Indicates errors on PROFIBUS DP. The LED is lit when: <ul style="list-style-type: none"> The connection between the DP master and the CP 242-8 has broken down or the DP master is not active. The CP 242-8 was not or was incorrectly configured/assigned parameters by the DP master.
DIA (yellow)	Diagnostics	The LED is lit when the CP 242-8 indicates diagnostic information to the DP master. Diagnostic information is reported by the CP 242-8 when the bit PLC_RUN=0 (see Section 2.3.4); this is always the situation when the S7-200 CPU is in the STOP mode.
SF (red)	System error	The LED is lit when: <ul style="list-style-type: none"> The CP 242-8 has detected an internal error (for example EEPROM defective). The CP 242-8 cannot currently make the mode change requested with the SET button (for example an AS-i slave with address 0 exists).
APF (red)	AS-i Power Fail	This indicates that the voltage supplied to the AS-i cable by the AS-i power supply unit is too low or there is a complete power outage.

Table 1-2 , (continued)

LED (color)	Status	Meaning
CER (yellow)	Configuration Error	<p>This LED indicates whether the slave configuration detected on the AS-i cable matches the expected configuration on the CP 242-8. If they do not match, the CER LED is lit.</p> <p>The CER LED is lit in the following situations:</p> <ul style="list-style-type: none"> • When a configured AS-i slave does not exist on the AS-i cable (for example failure of the slave). • When an AS-i slave exists on the AS-i cable but it was not previously configured. • When an attached AS-i slave has different configuration data (I/O configuration, ID code) from the slave configured on the CP 242-8. • When the CP 242-8 is in the offline phase.
AUP (green)	Autoprogramming available	<p>In the protected mode of the CP 242-8, this indicates that automatic address programming of an AS-i slave is possible. The automatic address programming makes it much easier to exchange a defective AS-i slave on the AS-i cable (for more detailed information refer to Chapter 5.1).</p>
CM (yellow)	Configuration Mode	<p>This LED displays the mode of the CP 242-8.</p> <ul style="list-style-type: none"> • LED lit: Configuration Mode • LED unlit: Protected Mode <p>The configuration mode is only required for installing and starting up the CP 242-8. In the configuration mode, the CP 242-8 activates all connected AS-i slaves and exchanges data with them. For more information about the configuration mode, refer to Section 1.8.</p>

Note

If there are no errors detected in the protected mode of the CP 242-8, **all** LEDs are off.

1.7.2 Slave Display for AS-i Slaves

Interpreting the slave display status

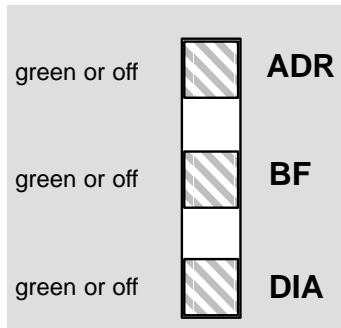

The slave display can be recognized by the fact that at least one group LED is lit green and that the ADR LED is not red.

The lower 5 LEDs then indicate the slaves on the AS-Interface. In this case, the label to the left of the LEDs applies. The display always represents 5 slaves.

Display Statuses and Operation in Detail

The AS-i slaves are displayed in groups of five. The upper three group LEDs indicate (in green) which of the groups of 5 is displayed. The lower five LEDs are lit green to indicate the detected or active AS-i slaves within the group.

- You can move from group to group by pressing the DISPLAY button again.
- The module returns to the status display in the following situations:
 - After displaying the last group (AS-i slaves 30, 31) and pressing the DISPLAY button twice. (In other words changing to the PROFIBUS address display and then to the status display.)
 - If you do not press the DISPLAY button for approximately 8 minutes.

Characteristics of the Slave Display

- If the CP 242-8 is in the **configuration mode**, all **detected** AS-i slaves are displayed.
- If the CP 242-8 is in the **protected mode**, all **active** AS-i slaves are displayed. In the protected mode, failed or existing but unconfigured AS-i slaves are indicated by the corresponding LED flashing.

Example of a Slave Display

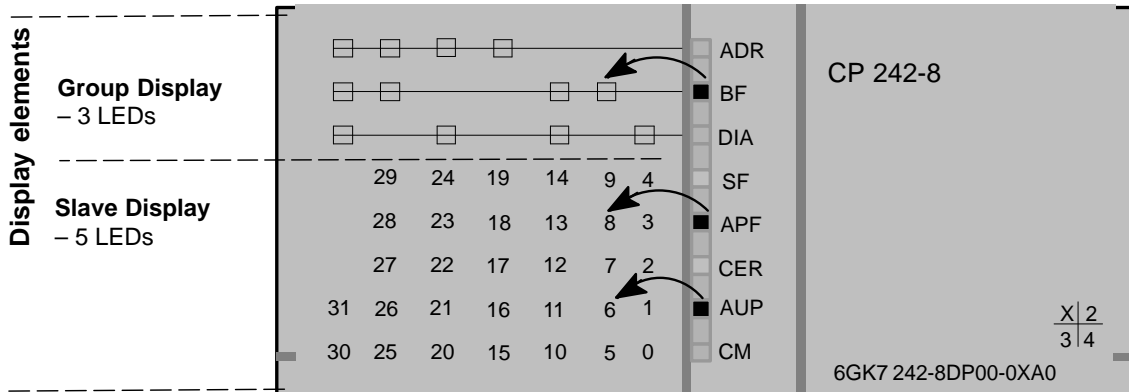

Figure 1-4 Example of a Slave Display

From the display you can obtain the following information:

- The group LEDs indicate the second group of five.
- Within this group, the active AS-i slaves 6 and 8 are displayed by the lower five LEDs.

1.7.3 Displaying and Setting the PROFIBUS Address

Interpreting the PROFIBUS Address Display

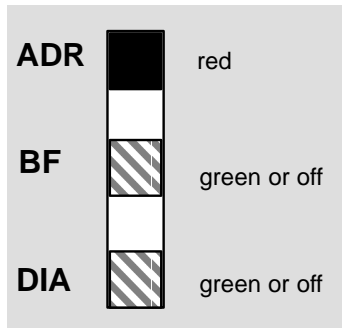

If the top LED ("ADR") of the group display is lit up red, the 7 lower LEDs indicate the PROFIBUS address of the CP 242-8 in **binary** format.

Setting the PROFIBUS Address

To set the PROFIBUS address of the CP 242-8, follow the steps outlined below:

1. Switch the S7-200 CPU to STOP. This ensures that bit PLC_RUN = 0.

Note

It is only possible to set the PROFIBUS address in this mode PLC_RUN = 0 (see also Section 2.3.4)!

2. Change the display on the CP 242-8 until the "ADR" LED is lit red by pressing the DISPLAY button.

The CP 242-8 then indicates the currently set PROFIBUS address using the 7 lower LEDs.

3. If you now press the DISPLAY button, the CP 242-8 returns to the status display, the set PROFIBUS address is retained.

If, on the other hand, you press the SET button, you can set a new value for the PROFIBUS address. First of all, the "BF" LED flashes and the most significant bit of the PROFIBUS address is displayed.

4. If you press the SET button, this bit is set (LED on), if you press the DISPLAY button, the bit is reset (LED off). The display then jumps to the "DIA" LED (next address bit of the PROFIBUS address).
5. By following the steps outlined above, you can now set or reset each of the individual bits of the PROFIBUS address.
6. Once you have entered all the bits, the display of the set address bits flashes changing quickly between red/green or yellow/green. If you press the SET button again, the set PROFIBUS address is adopted by the CP 242-8. If, on the other hand, you press the DISPLAY button, the new address is discarded. The entry of the new address must then be repeated (as in steps 4 and 5).

The value of the address bits represented by the LEDs of the PROFIBUS address is illustrated in the following example:

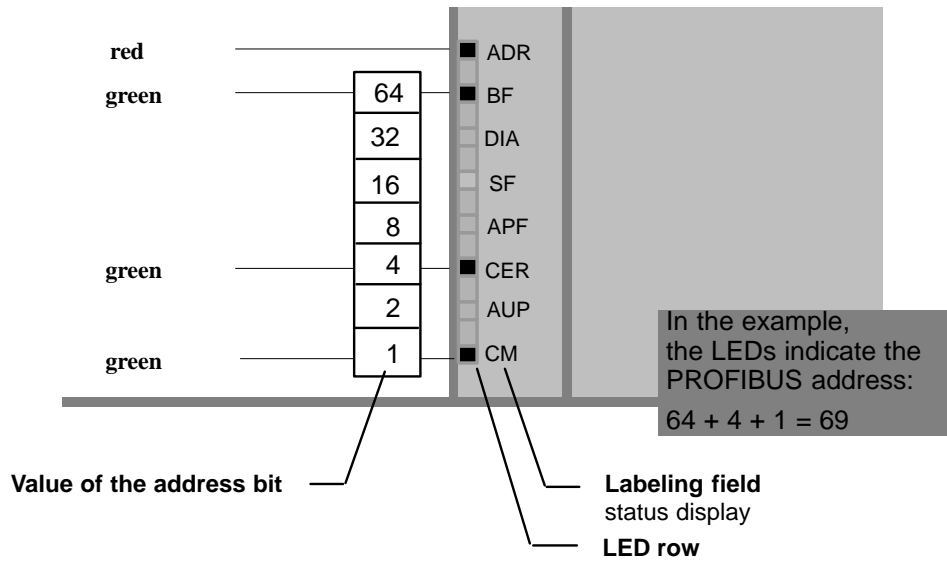

Figure 1-5

In the example above, the PROFIBUS address 69 was set with the SET/DISPLAY buttons.

The highest address that can be set is address 126. Remember that address 126 is reserved on PROFIBUS for special functions (address assignment). For data exchange with a DP master, you can use addresses 1 to 125.

1.8 Configuring the AS-Interface with the SET Button

Interpreting the Display Status

The CP 242-8 can adopt two modes on the AS-Interface:

- Configuration Mode
- Protected Mode

When you press the SET button, the mode is changed.

Note

The SET button is only effective when the bit PLC_RUN = 0 is set in the control byte of the CP 242-8. This is always the case, when the S7 – 200 CPU is in the STOP mode.

Configuration Mode

The configuration mode is used during AS-i installation and startup.

In the configuration mode, the CP 242-8 can exchange data with every AS-i slave connected to the AS-i cable (except for the AS-i slave with address '0'). Any AS-i slaves that are added later are detected immediately by the master and activated and included in the cyclic data exchange.

When installation and startup is completed, the CP 242-8 can be switched to the protected mode using the SET button. Any AS-i slaves active at this point are therefore configured. The following data are stored on the CP 242-8 in non-volatile memory:

- The addresses of the AS-i slaves
- the ID codes
- the I/O configuration
- The current slave parameters

Protected Mode

If the CP 242-8 is in the protected mode, it only exchanges data with slaves that are "configured". In this sense, "configured" means that the slave addresses stored on the CP 242-8 and the configuration data stored on the CP 242-8 match the values of the existing AS-i slaves.

Preparing to Configure

Make sure that the following situation applies:

- The S7-200 CPU must be set to STOP (PLC_RUN=0).
- The CP 242-8 and all AS-i slaves must be connected to the AS interface and supplied with power by the AS-i power supply unit.

Note

It is only possible to configure the AS interface with the status display and slave display status. The CP 242-8 must not be in the PROFIBUS address display mode, in other words when the SET button is pressed, the "ADR" LED display must not be lit red.

Configuring

1. Press the DISPLAY button to set the CP 242-8 display to the "status display" mode (initial status).
2. Check whether the CP 242-8 is in the "configuration mode". ("CM" LED lit). If not, change the CP 242-8 to the configuration mode using the SET button.
3. By changing to the slave display with the DISPLAY button, you can check whether all the slaves connected to the AS-Interface exist.
4. Press the SET button. This configures the CP 242-8.

At the same time, the CP 242-8 is switched to the protected mode, the "CM" LED goes off.

The "CER" LED also goes off since the "expected configuration" stored on the CP 242-8 after configuration matches the existing "actual configuration" on the AS-Interface.

Note

Configuring the CP 242-8 during AS-i Power Fail (this is, for example, the case when the AS-i power supply unit is turned off or when the CP 242-8 is not connected to the AS-Interface) resets the configuration of the CP 242-8. This means the following:

- There are no AS-i slaves configured
 - All AS-i slave parameters are set
 - The automatic address programming is activated.
-

Note

Changing from the configuration mode to the protected mode is only possible when there is no AS-i slave with address 0 connected to the AS-Interface. If a slave 0 is connected, the "SF" LED is lit when the SET button is pressed.



Interface to the User Program in the S7-200 CPU

2

2.1	CP 242-8 Connects the S7-200 CPU to PROFIBUS DP and AS-Interface	2-2
2.2	Addressing the CP 242-8 in the S7-200 CPU	2-4
2.3	Meaning of the Data in the Digital Module	2-7
2.3.1	Identification Register in the Digital Module	2-8
2.3.2	Error Register in the Digital Module	2-9
2.3.3	Status Byte (Input Register 8DI)	2-11
2.3.4	Control Byte (Output Register 8DO)	2-13
2.4	Meaning of the Data in the Analog Module	2-14
2.4.1	Identification Register in the Analog Module	2-15
2.4.2	Error Register in the Analog Module	2-16
2.5	Access to the Analog Input and Output Words	2-17
2.5.1	Analog Input Area	2-18
2.5.2	Analog Output Area	2-20

2.1 CP 242-8 Connects the S7-200 CPU with PROFIBUS DP and AS-Interface

CP 242-8 as Expansion Module in the S7-200

The CP 242-8 occupies 2 consecutive expansion module slots in the S7-200:

- Digital module 8DI/8DO
- Analog module 8AI/8AO

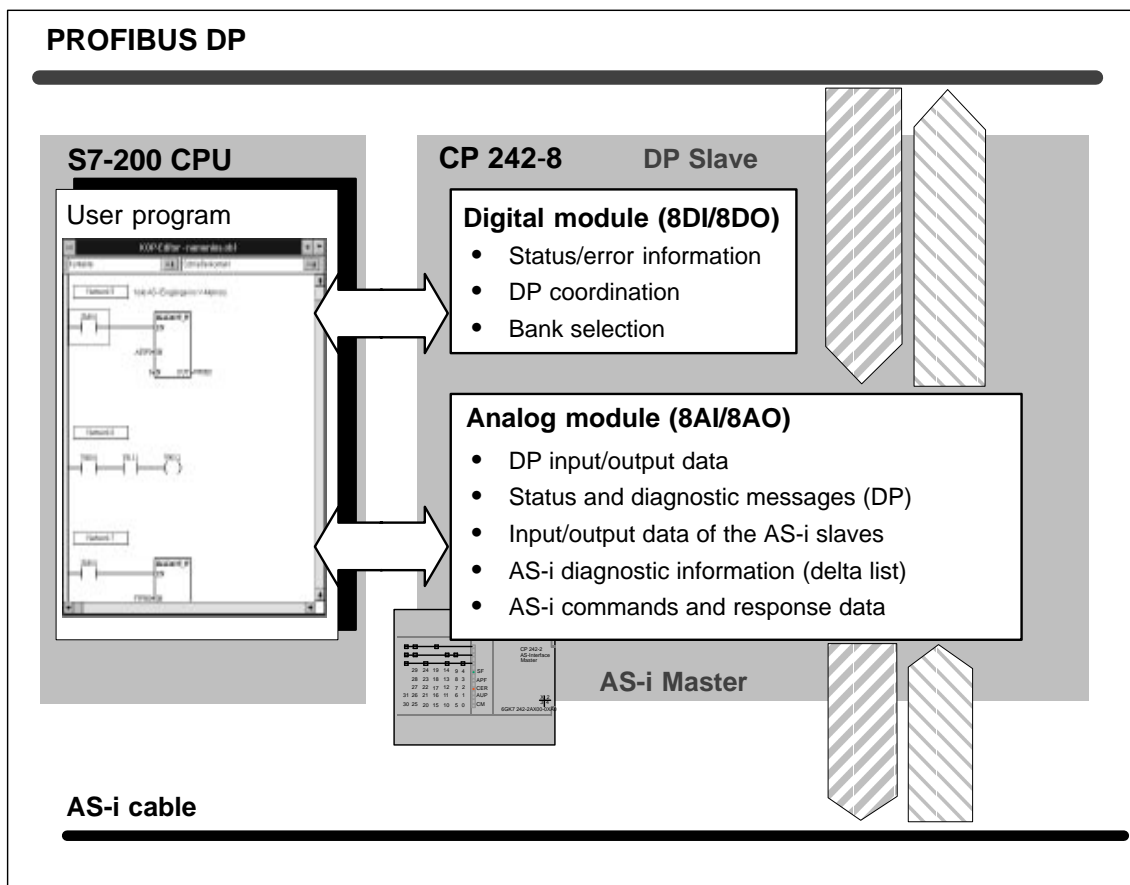

Figure 2-1

Digital Module

The digital module occupies 8 input and 8 output bits in the address area of the digital inputs and outputs. The S7-200 CPU and the CP 242-8 are coordinated via the digital module.

The data to be addressed in the analog module by the user program is selected using bank select bits.

Analog Module

The analog module occupies 16 input and 16 output bytes in the address area of the analog inputs and outputs. The data exchange both with the PROFIBUS DP master and the AS-i slaves is handled via the analog module (see Figure 2-1).

The bank select mechanism means that a larger data area in total can be addressed in the analog module than the addressable data area in the S7-200 CPU for the expansion module.

2.2 Addressing the CP 242-8 in the S7-200 CPU

Address Areas

The start addresses of the address areas are determined by the following:

- The type of S7-200 CPU being used
- The slot of the CP 242-8 in the S7-200.

Examples

The following table contains examples of the addresses of the digital and analog input/output areas with the possible configurations with a CPU 212 and CPU 214.

- Example of a CPU 212 and a CP 242-8

CPU 212		CP 242-8			
8DI	8 DO	8DI	8DO	8AI	8AO
I0.0	Q0.0	I1.0	Q1.0	AIW0	AQW0
I0.1	Q0.1	I1.1	Q1.1	AIW2	AQW2
I0.2	Q0.2	I1.2	Q1.2	AIW4	AQW4
I0.3	Q0.3	I1.3	Q1.3	AIW6	AQW6
I0.4	Q0.4	I1.4	Q1.4	AIW8	AQW8
I0.5	Q0.5	I1.5	Q1.5	AIW10	AQW10
I0.6	Q0.6	I1.6	Q1.6	AIW12	AQW12
I0.7	Q0.7	I1.7	Q1.7	AIW14	AQW14

- Example of a CPU 214 and a CP 242-8 inserted directly beside the CPU

CPU 214		CP 242-8			
14DI	10 DO	8DI	8DO	8AE	8AO
I0.0	Q0.0	I2.0	Q2.0	AIW0	AQW0
I0.1	Q0.1	I2.1	Q2.1	AIW2	AQW2
I0.2	Q0.2	I2.2	Q2.2	AIW4	AQW4
I0.3	Q0.3	I2.3	Q2.3	AIW6	AQW6
I0.4	Q0.4	I2.4	Q2.4	AIW8	AQW8
I0.5	Q0.5	I2.5	Q2.5	AIW10	AQW10
I0.6	Q0.6	I2.6	Q2.6	AIW12	AQW12
I0.7	Q0.7	I2.7	Q2.7	AIW14	AQW14
I1.0	Q1.0				
I1.1	Q1.1				
I1.2					
I1.3					
I1.4					
I1.5					

- Example of a CPU 214, a CP 242-2 and a CP 242-8

CPU 214		CP 242-2				CP 242-8			
14DI	10 DO	8DI	8DO	8AI	8AO	8DI	8DO	8AI	8AO
I0.0	Q0.0	I2.0	Q2.0	AIW0	AQW0	I3.0	Q3.0	AIW16	AQW16
I0.1	Q0.1	I2.1	Q2.1	AIW2	AQW2	I3.1	Q3.1	AIW18	AQW18
I0.2	Q0.2	I2.2	Q2.2	AIW4	AQW4	I3.2	Q3.2	AIW20	AQW20
I0.3	Q0.3	I2.3	Q2.3	AIW6	AQW6	I3.3	Q3.3	AIW22	AQW22
I0.4	Q0.4	I2.4	Q2.4	AIW8	AQW8	I3.4	Q3.4	AIW24	AQW24
I0.5	Q0.5	I2.5	Q2.5	AIW10	AQW10	I3.5	Q3.5	AIW26	AQW26
I0.6	Q0.6	I2.6	Q2.6	AIW12	AQW12	I3.6	Q3.6	AIW28	AQW28
I0.7	Q0.7	I2.7	Q2.7	AIW14	AQW14	I3.7	Q3.7	AIW30	AQW30
I1.0	Q1.0								
I1.1	Q1.1								
I1.2									
I1.3									
I1.4									
I1.5									

- Example of a CPU 214, one 8DI module, one 3AI/1AO module and a CP 242-8

CPU 214		Module	Module		CP 242-8			
14DI	10 DO	8DI	3AI	1AO	8DI	8DO	8AI	8AO
I0.0	Q0.0	I2.0	AIW0	AQW0	I3.0	Q2.0	AIW16	AQW16
I0.1	Q0.1	I2.1	AIW2		I3.1	Q2.1	AIW18	AQW18
I0.2	Q0.2	I2.2	AIW4		I3.2	Q2.2	AIW20	AQW20
I0.3	Q0.3	I2.3			I3.3	Q2.3	AIW22	AQW22
I0.4	Q0.4	I2.4			I3.4	Q2.4	AIW24	AQW24
I0.5	Q0.5	I2.5			I3.5	Q2.5	AIW26	AQW26
I0.6	Q0.6	I2.6			I3.6	Q2.6	AIW28	AQW28
I0.7	Q0.7	I2.7			I3.7	Q2.7	AIW30	AQW30
I1.0	Q1.0							
I1.1	Q1.1							
I1.2								
I1.3								
I1.4								
I1.5								

- Example of a CPU 216, one CP 242-8

CPU 216		CP 242-8			
24DI	16 DO	8DI	8DO	8AI	8AO
I0.0	Q0.0	I3.0	Q2.0	AIW0	AQW0
I0.1	Q0.1	I3.1	Q2.1	AIW2	AQW2
I0.2	Q0.2	I3.2	Q2.2	AIW4	AQW4
I0.3	Q0.3	I3.3	Q2.3	AIW6	AQW6
I0.4	Q0.4	I3.4	Q2.4	AIW8	AQW8
I0.5	Q0.5	I3.5	Q2.5	AIW10	AQW10
I0.6	Q0.6	I3.6	Q2.6	AIW12	AQW12
I0.7	Q0.7	I3.7	Q2.7	AIW14	AQW14
I1.0	Q1.0				
I1.1	Q1.1				
I1.2	Q1.2				
I1.3	Q1.3				
I1.4	Q1.4				
I1.5	Q1.5				
I1.6	Q1.6				
I1.7	Q1.7				
I2.0					
I2.1					
I2.2					
I2.3					
I2.4					
I2.5					
I2.6					
I2.7					

2.3 Meaning of the Data in the Digital Module

Overview

The digital module of the CP 242-8 consists of four registers:

- Identification register, 8 bits (I/O module identifier)
- Error register, 8 bits
- Input register, 8DI (status byte of the CP 242-8)
- Output register, 8DO (control byte of the CP 242-8)

Essentially, the functions shown in the following diagram are handled via this register:

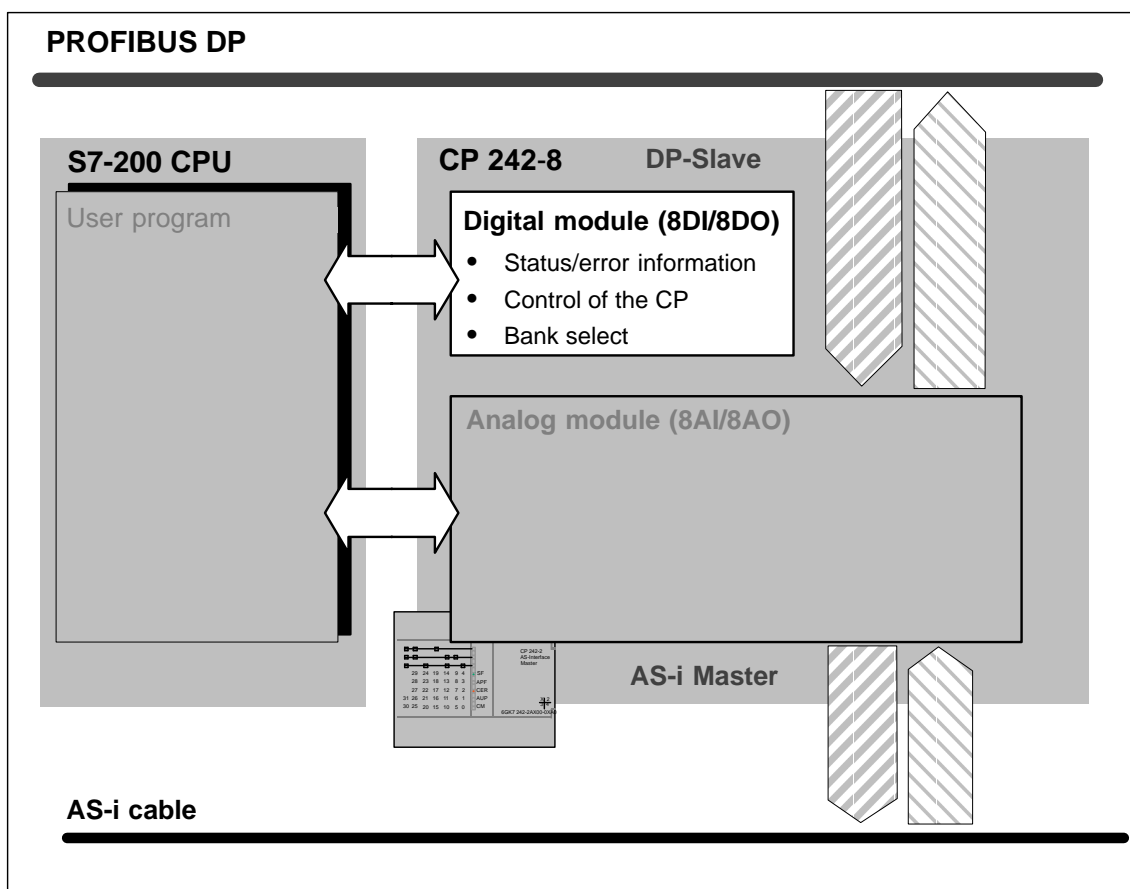

Figure 2-2

2.3.1 Identification Register in the Digital Module

Meaning

The identification register signals the I/O module identifier to indicate the existence of an 8DI/8DO digital module with the value specified below.

The address at which the program can access the identification register depends on the slot in which the CP 242-8 is inserted.

For further information about the special bit memory and its structure for I/O modules refer to/5/.

Range of Values

The identification register can be read via the special bit memory of the S7-200 CPU. It provides the fixed value **05H**.

Example

Situation: The CP 242-8 is inserted directly beside the S7-200 CPU.

The content of the identification register can be read from SMB8.

2.3.2 Error Register in the Digital Module

Meaning for the User Program

With this register, the CP 242-8 signals errors to the user program.

Structure of the Error Register

Bit 7	Bit 6	Bit 5	Bit 4	Bit 3	Bit 2	Bit 1	Bit 0
0	0	0	0	DIA	APF	BF	CER

Key:



relevant for AS-i



relevant for DP



relevant for both

Bit Description/Range of Values

Table 2-1

Bit	Value	Meaning
CER	0	AS-i configuration correct (only in the protected mode) The "CER" LED is off
	1	AS-i configuration error (only in the protected mode) This indicates a difference between the slave configuration detected on the AS-i cable and the desired configuration configured on the CP 242-8. The "CER" LED is lit (see Section 1.7.1 Status Display of the CP 242-8).
BF	0	The CP 242-8 has correct parameters and is correctly configured. Cyclic data exchange with the PROFIBUS DP master is active.
	1	Can have the following meaning: <ul style="list-style-type: none"> The connection between the DP master and the CP 242-8 has broken down or the DP master is not active. The CP 242-8 was not or was incorrectly configured/assigned parameters by the DP master.
APF	0	AS-i voltage correct The "APF" LED is off.
	1	AS-i Power Fail; This indicates that the voltage supplied on the AS-i cable by the AS-i power supply unit is too low or there is a complete power outage. The "APF" LED is lit (see Section 1.7.1 Status Display of the CP 242-8).

Table 2-1 , (continued)

Bit	Value	Meaning
DIA	0	The CP 242-8 is not indicating diagnostic information.
	1	The CP 242-8 is indicating diagnostic information. Diagnostic information is signaled by the CP 242-8 when bit PLC_RUN=0 is set (see Section 2.3.4). This is the case when the S7-200 CPU is in the STOP mode.

Note

The "CER" bit indicates configuration errors only in the protected mode. In the configuration mode, the "CER" bit is always "0".

The "CER" LED, on the other hand, indicates configuration errors both in the configuration mode and in the protected mode.

Example of Access to the Error Register

Situation: The CP 242-8 is inserted directly beside the S7-200 CPU

Evaluate the special memory bits SM9.0 to SM9.4 in the SM area (for more information about the special bit memory area of the S7-200 CPU, refer to /5/).

If an error has occurred one or more of these bits is set.

2.3.3 Status Byte (Input Register 8DI)

Meaning for the User Program

This register indicates the status of the CP 242-8 in terms of the AS-i master interface and the DP slave interface.

Structure of the Status Byte

Bit 7	Bit 6	Bit 5	Bit 4	Bit 3	Bit 2	Bit 1	Bit 0
0	ASI_RESP	DP_RESP	DP_CONS	DP_STATE 1	DP_STATE 0	CP_READY	ASI_MODE

Key:



relevant for AS-i



relevant for DP



relevant for both

Description of the Bits

Table 2-2

Bit	Value		Meaning
ASI_MODE	0		The CP 242-8 is in the protected mode.
	1		The CP 242-8 is in the configuration mode.
CP_READY	0		The CP 242-8 is not yet operational after turning on the power supply. Evaluation of the I/O data or other information from the CP is not permitted.
	1		The CP 242-8 is ready for operation.
DP_STATE 1 / 0	Status of the PROFIBUS DP interface		
	0	0	After turning on the CP 242-8, no communication between the DP master and the CP 242-8 has yet taken place. (for example parameter assignment, configuration).
	0	1	Parameter assignment or configuration error. Check the correct configuration of the PROFIBUS DP master.
	1	0	Cyclic data exchange between the DP master and CP 242-8 is active.
	1	1	Cyclic data exchange between the DP master and CP 242-8 is interrupted.
DP_CONS	0		The PROFIBUS DP master is exchanging byte -consistent data with the CP 242-8.
	1		The PROFIBUS DP master is exchanging block -consistent data with the CP 242-8.

Table 2-2 , (continued)

Bit	Value	Meaning
DP_RESP	0/1	Response bit for consistent data transfer (see Section 3.5).
ASI_RESP	0/1	Response bit for the AS-i command interface (see Section 3.5).

2.3.4 Control Byte (Output Register 8DO)

Meaning for the User Program

The user program controls the data exchange with the CP 242-8 via this register.

Structure of the Status Byte

Bit 7	Bit 6	Bit 5	Bit 4	Bit 3	Bit 2	Bit 1	Bit 0
PLC_RUN	ASI_COM	DP_COM	0	BS3	BS2	BS1	BS0

Key:



relevant for AS-i



relevant for DP



relevant for both

Description of the Bits

Table 2-3

Bit	Value	Meaning
BS0..BS3	0 ... 15 dec.	Bank select bits for changing the bank in the analog module (see Section 2.5).
DP_COM	0/1	Job bit for block-consistent transfer of DP data (see Section 4.2.2).
ASI_COM	0/1	Job bit for the AS-i command interface (see Section 3.5).
PLC_RUN	In the STOP mode of the S7-200, the CP must send the value '0' to all AS-i slaves. Since the AS-i slave data are transferred via the analog area and the S7-200 CPU does not set this area to '0' when it changes from RUN to STOP, the CPU state is signaled to the CP 242-8 using the PLC_RUN bit as follows:	
	0	Signal to the CP 242-8 that the S7-200 CPU is in the STOP mode. The CP 242-8 sends '0' to all AS-i slaves. The S7-200 CPU sets the bit to "0" automatically when there is a change from RUN to STOP. If PLC_RUN=0, the CP 242-8 indicates diagnostic information on PROFIBUS DP (see Section 4.7).
	1	Signals to the CP 242-8 that the S7-200 CPU is in the RUN mode. The CP 242-8 sends the content of output bank 0 to all AS-i slaves (see Section 2.4). The user program must set this bit to "1" during startup (first scan). Do not set the PLC_RUN bit permanently to "1" with the S7-200 operating system functions such as "CPU configuration/setting the outputs" or "force outputs".

2.4 Meaning of the Data in the Analog Module

Overview

The analog module of the CP 242-8 consists of four areas:

- Identification register, 8 bits (I/O module identifier)
- Error register, 8 bits
- 8 analog input words (8 AI)
- 8 analog output words (8 AO)

The most important functions handled via these areas are shown in the diagram below:

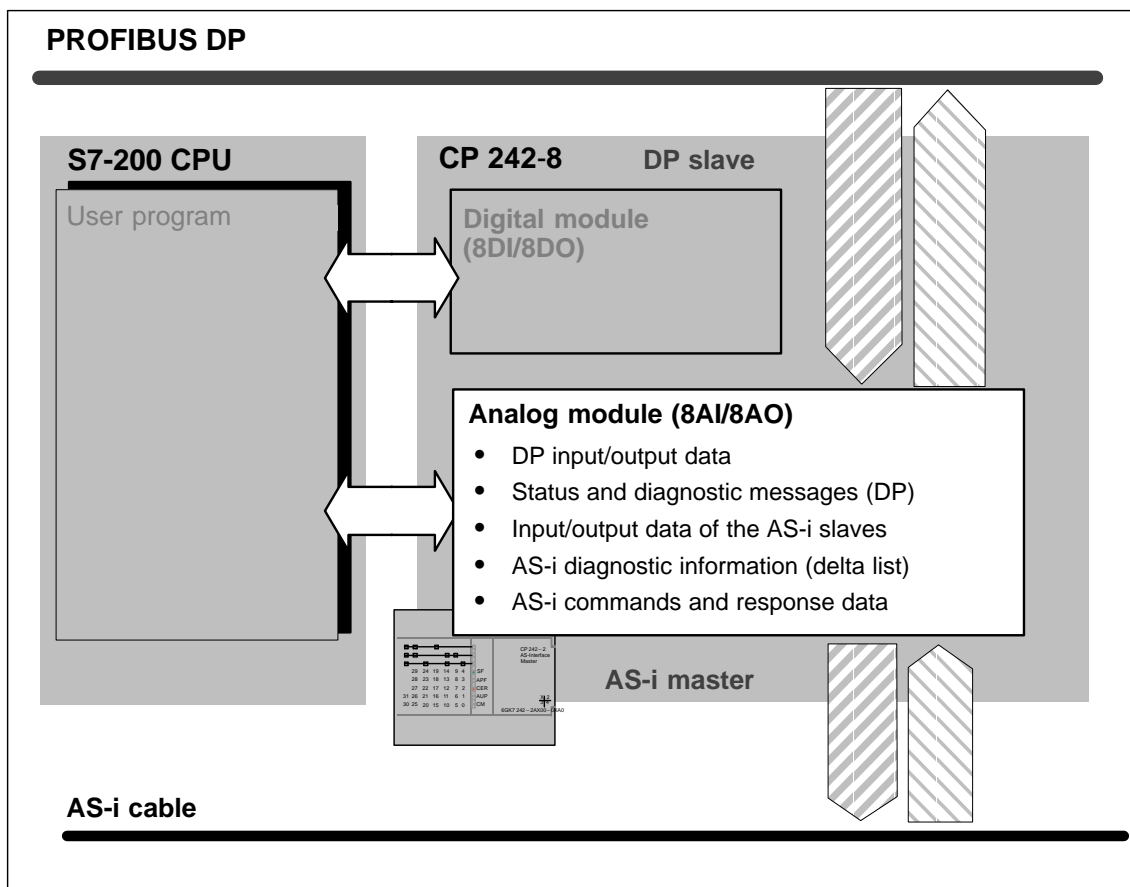

Figure 2-3

2.4.1 Identification Register in the Analog Module

Meaning

The identification register signals the I/O module identifier to indicate the existence of an 8AI/8AO analog module with the value specified below.

The address at which the program can access the identification register depends on the slot of the CP 242-8.

For further information about the special bit memory and its structure for I/O modules, refer to /5/.

Range of values

The identification register can be read via the special bit memory area of the S7-200 CPU. It provides the fixed value **1FH**.

Example

Situation: The CP 242-8 is inserted directly beside the S7-200 CPU.

The content of the identification register can be read via SMB8.

2.4.2 Error Register in the Analog Module

Note

The error register of the analog module supplies the same information about error states on the DP interface and AS-Interface as the error register of the digital module.

For information about the coding, refer to Section 2.3.2.

2.5 Access to the Analog Input and Output Words

Principle

Using a bank-select mechanism, the 8 analog input words and the 8 analog output words can be switched to 16 different analog input areas and 16 different analog output areas on the CP 242-8.

Each of these banks is 8 words long.

Advantage

This bank-select mechanism has the advantage that the analog data area of 8 words available for the expansion module is increased according to the number of banks.

Access in the User Program

The switchover to the various banks is made using BS3–BS0 in the control byte of the CP 242-8 (see Section 2.3.4).

The four bank select bits are binary coded and select banks as shown below:

BS3	BS2	BS1	BS0	Bank No.
0	0	0	0	Bank 0 selected
0	0	0	1	Bank 1 selected
0	0	1	0	Bank 2 selected
0	0	1	1	Bank 3 selected
0	1	0	0	Bank 4 selected
0	1	0	1	Bank 5 selected
0	1	1	0	Bank 6 selected
0	1	1	1	Bank 7 selected
1	0	0	0	Bank 8 selected
1	0	0	1	Bank 9 selected
1	0	1	0	Bank 10 selected
1	0	1	1	Bank 11 selected
1	1	0	0	Bank 12 selected
1	1	0	1	Bank 13 selected
1	1	1	0	Bank 14 selected
1	1	1	1	Bank 15 selected



Caution

Make sure that the value of the bank select bits is located not only in the process output image but that it is also transferred to the CP 242-8 before you access the corresponding analog values (see example in Table 3-2).

2.5.1 Analog Input Area

Assignment of the Input Areas

The input area of the analog module of the CP 242-8 is mapped to the analog inputs of the user program using bank selection as shown below:

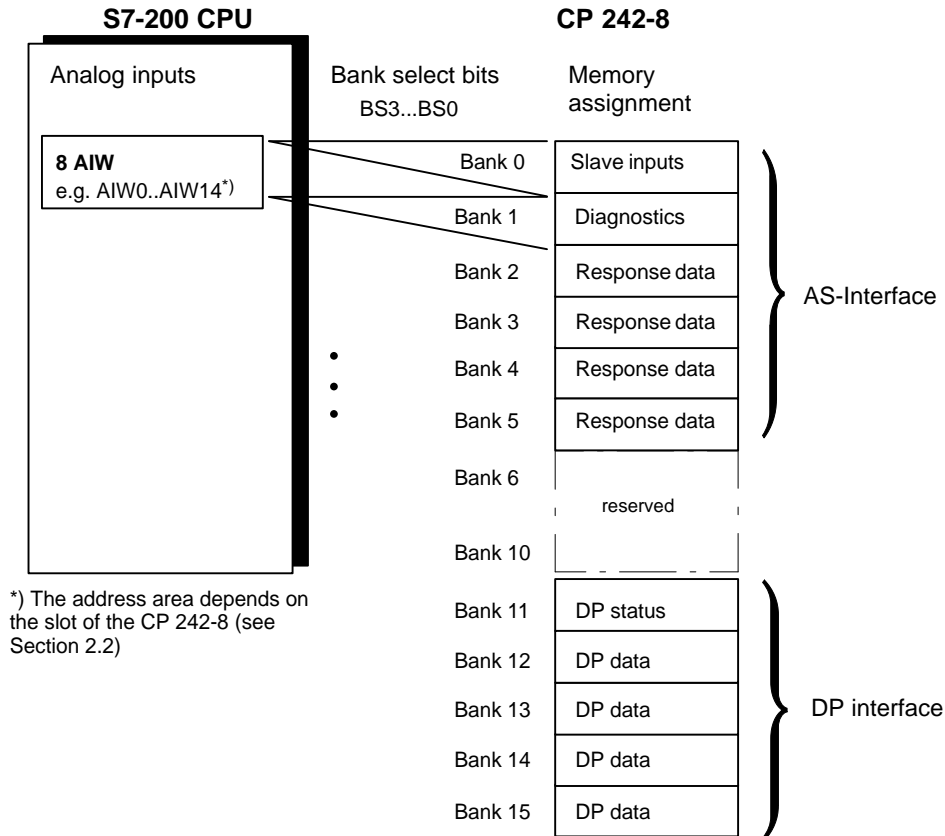

Figure 2-4

The bank select bits are set in the control byte of the digital module by the user program (see Section 2.3.4).

Bank 0: Input Data of the AS-i Slaves

With these analog input words, you can access the input bits of the AS-i slaves.

The structure is described in Section 3.2.

Bank 1: Diagnostics on the AS-Interface

The delta list of the AS-i slaves is indicated in this bank.

The delta list contains deviations of the existing AS-i slaves from the configuration on the CP 242-8.

By setting a bit, the following can be indicated:

- Missing slaves
- Extra slaves (not in the configuration)
- Slaves with incorrect I0/ID coding

The delta list is updated both in the configuration and in the protected mode.

The bytes and bits of the delta list are ordered as shown in the table below. (m: start address of the analog input area of the CP 242-8)

Byte \ Bit	Bit 7	Bit 6	Bit 5	Bit 4	Bit 3	Bit 2	Bit 1	Bit 0
Byte m+0	Slave 7	Slave 6	Slave 5	Slave 4	Slave 3	Slave 2	Slave 1	Slave 0
Byte m+1	Slave 15	Slave 14	Slave 13	Slave 12	Slave 11	Slave 10	Slave 9	Slave 8
Byte m+2	Slave 23	Slave 22	Slave 21	Slave 20	Slave 19	Slave 18	Slave 17	Slave 16
Byte m+3	Slave 31	Slave 30	Slave 29	Slave 28	Slave 27	Slave 26	Slave 25	Slave 24

Bank 2-5: Response Data on the AS-Interface

These banks contain the response data of the command calls. The data structures used and the codings are described in Section 3.6. The number of banks used depends on the particular command.

Bank 6-10: Reserved Area

These areas are reserved for later expansions and cannot be used.

Bank 11: DP Status

Status and diagnostic messages of the PROFIBUS DP interface (see Section 4.3).

Bank 12-15: Output Data from the PROFIBUS DP Master/Input Data for the S7-200

These areas are reserved for the data that is written by the DP master and read by the user program of the S7-200 (DP input data for the S7-200 user program).

Depending on the configuration on the DP master, this data area can be up to 64 bytes long.

The configuration decides whether these data are transferred with byte or block consistency (see Section 4.2).

2.5.2 Analog Output Area

Assignment of the Output Areas

The output area of the analog module of the CP 242-8 is mapped to the analog outputs of the user program using bank selection as follows:

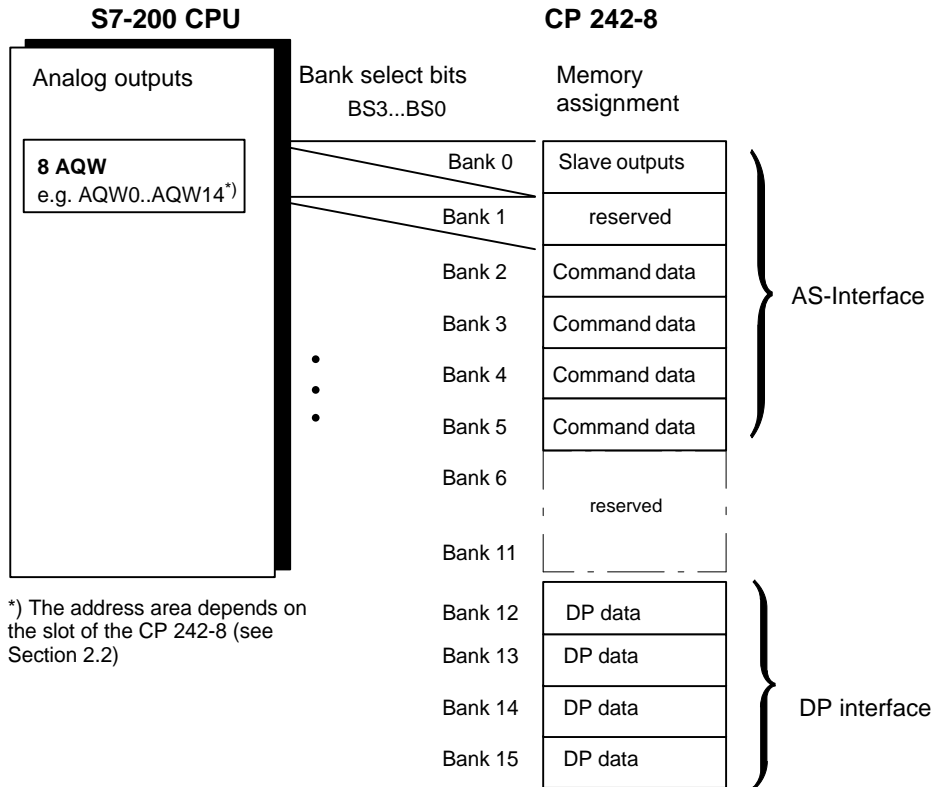

Figure 2-5

Bank 0: Output data for the AS-i slaves

With this analog output area, you can access the output bits of the AS-i slaves.

The structure is described in Section 3.2.

Bank 1: Reserved

This area is reserved for later expansions and cannot be used.

Bank 2-5: Data for AS-i Commands

Using this area, you can store command calls to the CP 242-8. The data structures used and the codings are described in Section 3.6. The number of banks used depends on the particular command.

Bank 6-11: reserved

These areas are reserved for later expansions and must not be used.

Bank 12-15: Output Data of the S7-200/Input Data for the PROFIBUS DP Master

These areas are reserved for addressing data written by the user program of the S7-200 and read by the DP master (output data).

Depending on the configuration on the DP master, this data area can be up to 64 bytes long.

In the configuration, you can also specify whether the data are transferred with byte or block consistency.



3

CP 242-8 as AS-Interface Master

3.1	About this Chapter	3-2
3.2	How the User Program Addresses the AS-i Slaves	3-3
3.3	Access to the AS-i User Data	3-6
3.4	Signaling Error and Diagnostic Information	3-7
3.5	Command Interface of the CP 242-8	3-9
3.6	Description of the AS-i commands	3-13
3.6.1	Set_Permanent_Parameter	3-18
3.6.2	Get_Permanent_Parameter	3-19
3.6.3	Write_Parameter	3-20
3.6.4	Read_Parameter	3-21
3.6.5	Store_Actual_Parameters	3-22
3.6.6	Set_Permanent_Configuration	3-23
3.6.7	Get_Permanent_Configuration	3-24
3.6.8	Store_Actual_Configuration	3-25
3.6.9	Read_Actual_Configuration	3-26
3.6.10	Set_LPS	3-27
3.6.11	Set_Offline_Mode	3-28
3.6.12	Select Autoprogramming	3-29
3.6.13	Set_Operation_Mode	3-30
3.6.14	Change_Slave_Address	3-31
3.6.15	Read Slave Status	3-32
3.6.16	Read Lists and Flags (Get_LPS, Get_LAS, Get_LDS, Get_Flags)	3-33
3.6.17	Read Total Configuration	3-35
3.6.18	Configure Total System	3-37
3.6.19	Write Parameter List	3-40
3.6.20	Read Parameter Echo List	3-41
3.6.21	Read Version ID	3-42
3.6.22	Read and Delete Slave Status	3-43
3.6.23	Read Slave ID	3-44
3.6.24	Read Slave I/O	3-45
3.6.25	Read Data and Delta List	3-46

3.1 About this Chapter

Standard Operation

This chapter explains the AS-i master interface of the CP 242-8. The chapter first deals with the addressing of the AS-i slaves and access to the I/O data of the slaves (known as standard operation). These functions are adequate for many applications.

AS-i Commands for Additional Functions

To be able to use all the functions possible with the AS-i master (master profile M1), additional AS-i commands are available. These are explained in Section 3.6.

3.2 Addressing the AS-i Slaves with the User Program

Requirements

Before you can access the I/O data of the AS-i slaves, the following requirements must be met:

- Set the “PLC_RUN” bit (bit 7) in the digital control byte to '1' at the beginning of the cyclic program.
- Leave the bank select bits (bits 0 to 3) in the digital control byte at '0'.
- Access to the I/O data of the slaves is then only allowed when the “CP_Ready” bit (bit 1) in the digital status byte is set to '1'.

The CP 242-8 assigns four bits (a nibble) in the input or output data area for each AS-i slave. The PLC can write (slave output data) and read (slave input data) this nibble.

This allows bi-directional slaves to be accessed.

Assignment of the AS-i Input Data (Bank 0 in the Analog Input)

Byte Number	Bits 7-4	Bits 3-0
m+0	reserved	Slave 1 Bit 3 Bit 2 Bit 1 Bit 0
m+1	Slave 2	Slave 3
m+2	Slave 4	Slave 5
m+3	Slave 6	Slave 7
m+4	Slave 8	Slave 9
m+5	Slave 10	Slave 11
m+6	Slave 12	Slave 13
m+7	Slave 14	Slave 15
m+8	Slave 16	Slave 17
m+9	Slave 18	Slave 19
m+10	Slave 20	Slave 21
m+11	Slave 22	Slave 23
m+12	Slave 24	Slave 25
m+13	Slave 26	Slave 27
m+14	Slave 28	Slave 29
m+15	Slave 30 Bit 3 Bit 2 Bit 1 Bit 0	Slave 31 Bit 3 Bit 2 Bit 1 Bit 0

m = the start address of the AS-i input data

Assignment of the AS-i Output Data (Bank 4 in the Analog Output)

Byte Number	Bits 7-4	Bits 3-0
n+0	reserved	Slave 1 Bit 3 Bit 2 Bit 1 Bit 0
n+1	Slave 2	Slave 3
n+2	Slave 4	Slave 5
n+3	Slave 6	Slave 7
n+4	Slave 8	Slave 9
n+5	Slave 10	Slave 11
n+6	Slave 12	Slave 13
n+7	Slave 14	Slave 15
n+8	Slave 16	Slave 17
n+9	Slave 18	Slave 19
n+10	Slave 20	Slave 21
n+11	Slave 22	Slave 23
n+12	Slave 24	Slave 25
n+13	Slave 26	Slave 27
n+14	Slave 28	Slave 29
n+15	Slave 30 Bit 3 Bit 2 Bit 1 Bit 0	Slave 31 Bit 3 Bit 2 Bit 1 Bit 0

m = the start address of the AS-i output data

Example

Bild 3-1 shows an example of the CP 242-8 addressing four AS-i slaves. In the example, the start addresses $m = 0$ for the input data and $n = 0$ for the output data are used.

The bits relevant for the user program (existing AS-i slaves) are shown on a gray background. The bits on a white background are irrelevant for the user program.

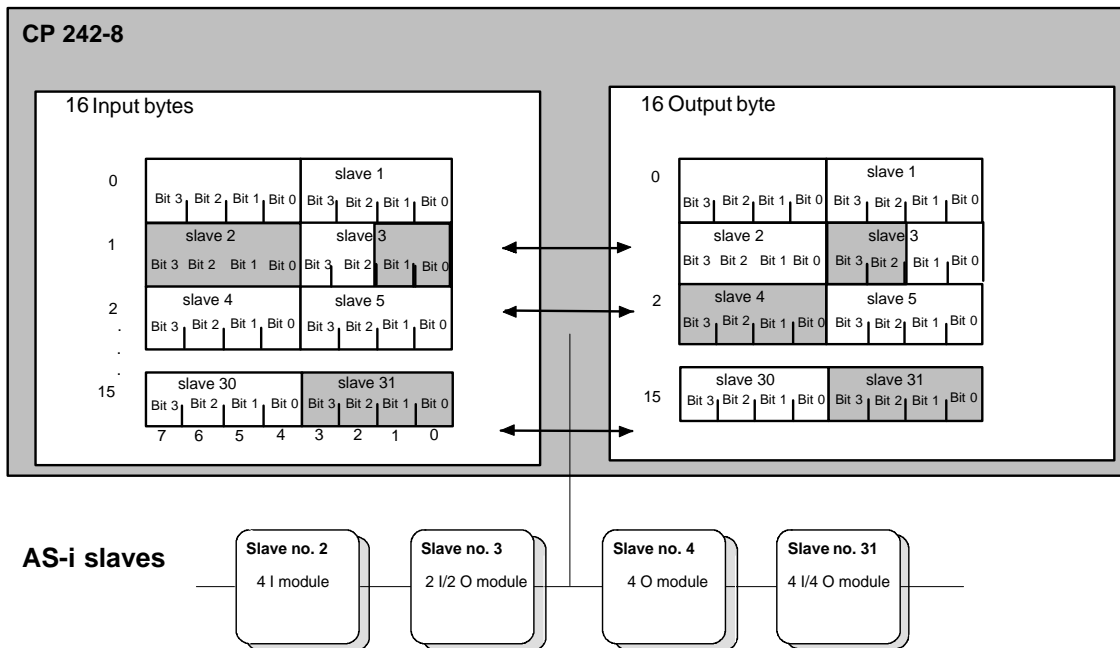
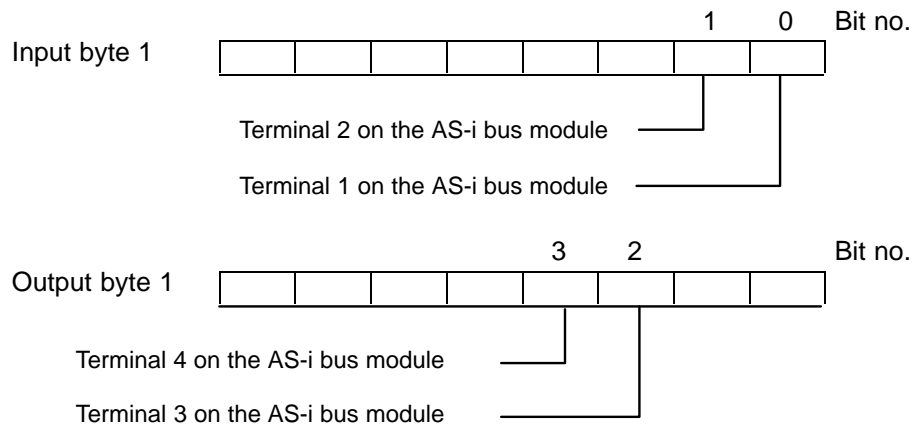

Figure 3-1

In the figure above, for example, the 2I/2O module (AS-i slave number 3 with two inputs and two outputs) occupies bits 0 and 1 in input byte 1 and bits 2 and 3 in output byte 1.

The assignment of the AS-i terminals of the bus modules to the data bits of the input/output bytes is shown below based on the example of slave number 3:



3.3 Access to the AS-i User Data

Formulating Data Access with STEP 7 Micro

You access the I/O data of the AS-i slaves using the analog commands of the "STEP 7 Micro" programming language.

Example

If you want to access individual bits of the slave data, you can use the method shown in the following sample program.

The following example in STL applies to a CPU 212 with a CP 242-8 plugged in directly beside it:

```

STL
-----
NETWORK 1          //Startup processing
LD  SM0.1          //if: first scan bit:
SI  Q1.7, 1        //PLC_RUN = 1
RI  Q1.0, 4        //select bank 0

NETWORK 2          //AS-i I/O processing
LD  I1.1           //if: CP 242-8_READY
CALL 1            //then: AS-i I/O processing
NETWORK           //End of main program
MEND

NETWORK 3          //Begin SBR "AS-i I/O processing"
SBR 1

NETWORK 4          //Fetch AS-i inputs to V memory
LD  SM0.0          //always 1
BMW  AIW0, VW800, 8 //transfer

NETWORK 5          //Examples of access to AS-i bits
LD  V800.0         //if bit 1 of slave 1
A   V815.1         //and bit 2 of slave 31
=   V903.2         //then bit 3 of slave 7 = 1

NETWORK 6          //Write from V memory to AS-i outputs
LD  SM0.0          //always 1
BMW  VW900, AQW0, 8 //transfer

NETWORK 7          //End of SBR "AS-i I/O processing"
RET

```

3.4 Signaling Errors and Diagnostic Information

Errors Signaled in the Error Register

If the CP 242-8 recognizes errors on the AS-Interface (AS-i slave failure, AS-i Power Fail) during operation, it signals these errors by resetting the input data of the affected slave and by setting the corresponding bit in the error register in the SM area (special bit memory).

The SM byte addresses depend on the slot of the CP 242-8.



Caution

Note that the operating system of the S7-200 CPU does not always update the error register in the SM area before a program cycle. For this reason, it is possible that the input data of an AS-i slave are set to '0' although no error is signaled in the error register.

If you require a consistent view of the input data, error bits and the delta list for programming your system, you can achieve this using the "Read Data and Delta List" command (see Section 3.6.25).

Example

The following example in STL applies to a CPU 212 with a CP 242-8 plugged in directly beside it:

If an AS-i configuration error occurs in the protected mode, the CP 242-8 sets bits SM9.0 and SM11.0 (both bits provide the user with the same information: AS-i configuration error).

To obtain more detailed information (which slave has failed), you can read in the delta list via bank 1 of the analog input area (see Section 2.5.1).

Table 3-1

STL	
NETWORK 1	//Startup processing
LD SM0.1	//if: first scan bit:
SI Q1.7, 1	//PLC_RUN = 1
RI Q1.0, 4	//select bank 0
NETWORK 2	//AS-i diagnostics
LD I1.1	//if: CP_READY
CALL 2	//then: AS-i diagnostics
NETWORK 3	//End of main program
MEND	
NETWORK 4	//Begin SBR "AS-i diagnostics"
SBR 2	
NETWORK 5	//Read delta list
LD SM0.0	//always 1
=I Q1.0	//select bank 1
BMW AIW0, VW816, 2	//read delta list
NOT	
=I Q1.0	//select bank 0
NETWORK 6	//Examples of access to the delta list:
LD V816.1	//if slave 1 has failed
O V819.7	//or if slave 31 has failed
= Q0.0	//then CPU output bit = 1
NETWORK 7	//End of SBR "AS-i diagnostics"
RET	

3.5 Command interface of the CP 242-8

Meaning

You require the AS-i command interface when you want to use functions over and above pure I/O data exchange with the AS-i slaves (for example assigning parameters to slaves from within the S7-200 program, modifying slave addresses etc.).

Command Buffer and Response Buffer

Command calls are made to the CP 242-8 from within the user program. You specify the command call in a command buffer and start the job.

The command buffer is in the analog output area of the CP 242-8 (for example starting at AQW0 if the CP 242-8 is plugged in directly beside the S7-200 CPU). Depending on the command to be executed (see Section 3.6), the response data occupy banks 2 to 5 in the analog output area of the CP 242-8.

On completion of the job, the job status and any response data are made available in a response buffer.

The response buffer is in the analog input area of the CP 242-8 (for example starting at AIW0, if the CP 242-8 is plugged in directly beside an S7-200 CPU). Depending on the command that was executed, the response data occupy banks 2 to 5 in the analog input area of the CP 242-8.

Requirements

Remember that the following requirements must be met before a command call is sent from within the user program:

- The PLC_RUN bit must be set to "1" in the control byte of the CP 242-8.
- By setting the CP_READY bit in the status byte to "1", the CP 242-8 signals that it is ready after turning on the power.

Note

If CP_READY is set to 0, no AS-i program execution is possible.

Command Sequence

The diagram below shows the following:

- How to execute commands in the user program
- How the CP 242-8 reacts to a command

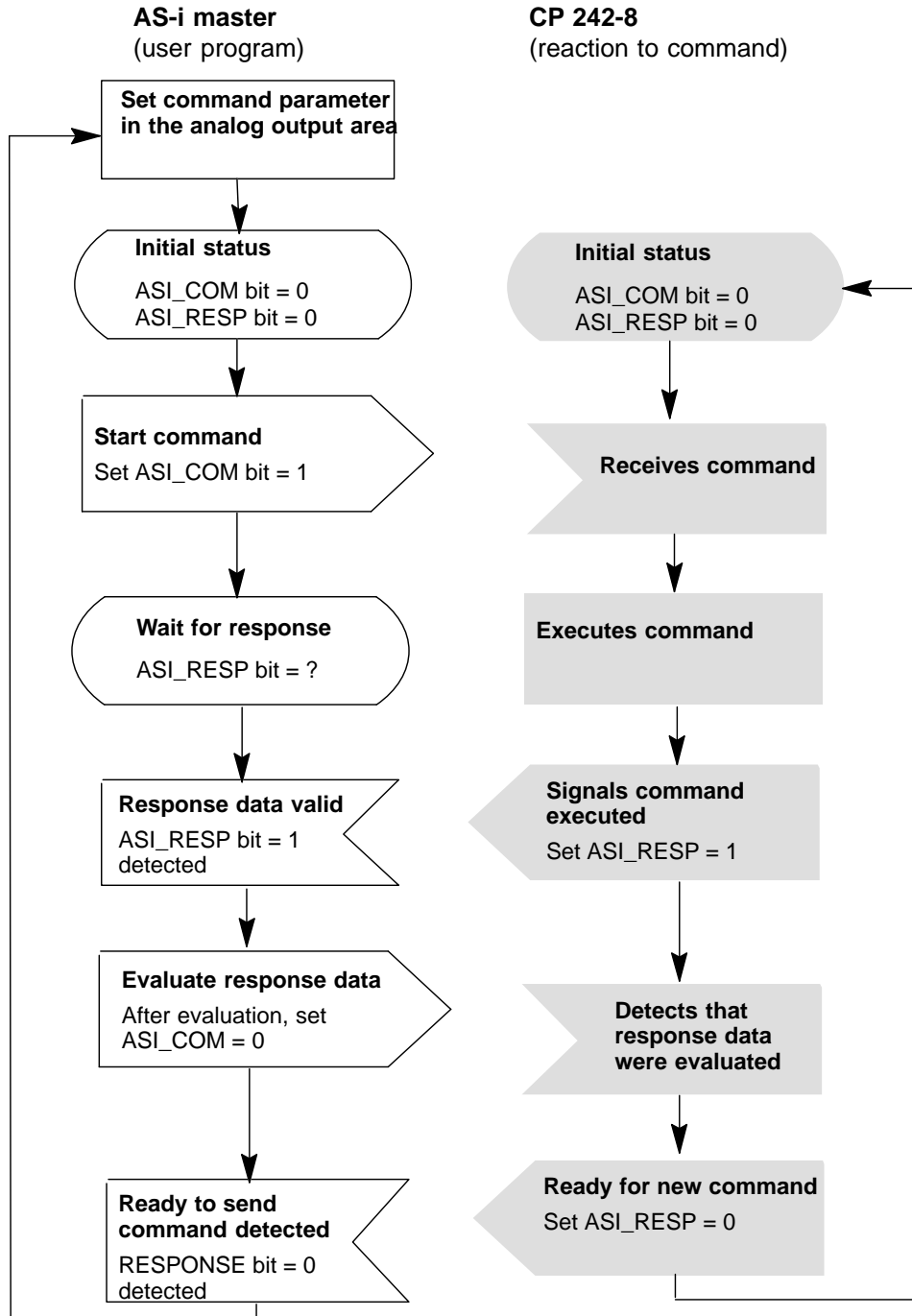

Figure 3-2

Note

A command started by the CP 242-8 is executed completely regardless of the state of the ASI_COM bit.

Note

The ASI_RESP bit is only reset by the CP 242-8 when the user program has set the ASI_COM bit to "0".

Example

The following example in STL applies to a CPU 212 with a CP 242-8 plugged in directly beside it:

The example shows the sequence of the Read_Lists_and_Flags command. Command execution is triggered by the positive edge at input 0.0.

To simply matters, 64 bytes are always transferred to the CP 242-8. When the response is read in from the CP 242-8, 64 bytes are also transferred.

Table 3-2

STL	
NETWORK 1	//Startup processing
LD SM0.1	//if: first scan bit:
SI Q1.7, 1	//PLC_RUN = 1
RI Q1.0, 4	//select bank 0
NETWORK 2	//AS-i command execution
LD I1.1	//if: CP_READY
MOVW 16#1000, VW932	//enter "read lists" code
CALL 3	//then: SBR 3
NETWORK 3	//End of main program
MEND	
NETWORK 4	//Begin SBR "AS-i command execution"
SBR 3	
NETWORK 5	//transfer the command data
LD I0.0	//If {trigger bit
EU	//pos. edge
AN Q1.6	//and not ASI_COM bit
AN I1.6	//ASI_RESP
	//the {
SI Q1.1, 1	//select bank 2
BMW VW932, AQW0, 8	//V memory -> bank
SI Q1.0, 1	//select bank 3
BMW VW948, AQW0, 8	//V memory -> bank
SI Q1.2, 1	//select bank 4
RI Q1.0, 2	//select bank 4
BMW VW964, AQW0, 8	//V memory -> bank
SI Q1.0, 1	//select bank 5
BMW VW980, AQW0, 8	//V memory -> bank
RI Q1.0, 4	//select bank 0
SI Q1.6, 1	//CP ASI_COM bit=1}
NETWORK 6	//Transfer the response data
LD Q1.6	//if{CP ASI_COM bit
A I1.6	//CP response bit}
	//then{
SI Q1.1, 1	//select bank 2
BMW AIW0, VW832, 8	//bank -> V memory
SI Q1.0, 1	//select bank 3
BMW AIW0, VW848, 8	//bank -> V memory
SI Q1.2, 1	//select bank 4
RI Q1.0, 2	//select bank 4
BMW AIW0, VW864, 8	//bank -> V memory
SI Q1.0, 1	//select bank 5
BMW AIW0, VW880, 8	//bank -> V memory
RI Q1.0, 4	//select bank 0
RI Q1.6, 1	//CP ASI_COM bit=0}
NETWORK 7	//End of SBR "AS-i command execution"
RET	

3.6 Description of the AS-i Commands

Overview

The following sections describe the AS-i command calls that can be sent by the S7-200 system to the CP 242-8. With these command calls, the CP 242-8 provides the complete functionality of the M1 master profile of the AS-i master specification. In addition to this, the CP 242-8 can be configured completely by the S7-200 system using command calls.

How to use the jobs is explained in the descriptions of the individual jobs, the PICS appendix and the detailed explanations in /1/ and /2/.

The commands that can be executed are listed in the following table:

Table 3-3

Name	Parameter	Return	Coding
Set_Permanent_Parameter -> description see Section 3.6.1	Slave address, parameter		0 0 H
Get_Permanent_Parameter -> description see Section 3.6.2	Slave address	Parameter	0 1 H
Write_Parameter -> description see Section 3.6.3	Slave address, parameter	Parameter echo (optional)	0 2 H
Read_Parameter -> description see Section 3.6.4	Slave address	Parameter value	0 3 H
Store_Actual_Parameters -> description see Section 3.6.5	none		0 4 H
Set_Permanent_Configuration -> description see Section 3.6.6	Slave address, configuration		0 5 H
Get_Permanent_Configuration -> description see Section 3.6.7	Slave address	Expected configuration data	0 6 H
Store_Actual_Configuration -> description see Section 3.6.8	none		0 7 H
Read actual configuration data -> description see Section 3.6.9	Slave address	Actual configuration data	0 8 H
Set_LPS -> description see Section 3.6.10	LPS		0 9 H
Set_Offline_Mode -> description see Section 3.6.11	Mode		0 A H
Select Autoprogramming -> description see Section 3.6.12	Mode		0 B H
Set_Operation_Mode -> description see Section 3.6.13	Mode		0 C H
Change_Slave_Address -> description see Section 3.6.14	Address 1, Address 2		0 D H

Table 3-3 , (continued)

Name	Parameter	Return	Coding
Read Slave Status -> description see Section 3.6.15	Slave address	Error record of the slave	0 F H
Read Lists and Flags (Get_LPS, Get_LAS, Get_LDS, Get_Flags) -> description see Section 3.6.16	none	LDS,LAS,LPS,flags	1 0 H
Read Total Configuration -> description see Section 3.6.17		Actual configuration data actual parameters LAS, flags	1 9 H
Configure Total System -> description see Section 3.6.18	Total configuration		1 A H
Write Parameter List -> description see Section 3.6.19	Parameter list		1 C H
Read Parameter Echo List -> description see Section 3.6.20	none	Parameter echo list	1 3 H
Read Version ID -> description see Section 3.6.21	none	Version string	1 4 H
Read and Delete Slave Status -> description see Section 3.6.22	Slave address	Error record of the slave	1 6 H
Read Slave ID -> description see Section 3.6.23	Slave address	ID code	1 7 H
Read Slave I/O -> description see Section 3.6.24	Slave address	I/O configuration	1 8 H
Read Data and Delta List -> description see Section 3.6.25	none	Error bits, input data delta list	1 D H

General Structure of the Command Buffer

The command buffer can extend over a maximum of 4 banks (2 to 5 in the analog module) with a maximum of 64 bytes depending on the command.

Table 3-4

Bank	Byte	Meaning / Content
2	0	Command number
	1	Parameter for job
	2	Parameter for job
	3	Parameter for job
	4	Parameter for job
	5	Parameter for job
	6	Parameter for job
	7	Parameter for job
	8	Parameter for job
	9	Parameter for job
	10	Parameter for job
	11	Parameter for job
	12	Parameter for job
	13	Parameter for job
	14	Parameter for job
15	Parameter for job	
3	0	Parameter for job
	:	Parameter for job
	15	Parameter for job
4	0	Parameter for job
	:	Parameter for job
	15	Parameter for job
5	0	Parameter for job
	:	Parameter for job
	15	Parameter for job

General Structure of the Response Buffer

The response buffer can extend over a maximum of 4 banks (2 to 5 in the analog module) with a maximum of 64 bytes depending on the command.

Table 3-5

Bank	Byte	Meaning / Content
2	0	Command number (echo)
	1	Command status
	2	Response data
	3	Response data
	4	Response data
	5	Response data
	6	Response data
	7	Response data
	8	Response data
	9	Response data
	10	Response data
	11	Response data
	12	Response data
	13	Response data
	14	Response data
15	Response data	
3	0	Response data
	:	Response data
	15	Response data
4	0	Response data
	:	Response data
	15	Response data
5	0	Response data
	:	Response data
	15	Response data

Command Status

Whether or not the job was executed correctly or errors occurred is signaled in the command status of the response buffer in byte 1.

Table 3-6

Value	Meaning
00H	Job completed without error.
81 H	Slave address incorrect.
82 H	Slave not activated (not in LAS).
83 H	Error on AS-Interface.
84 H	Command not permitted in the current state of the CP 242-8.
85 H	AS-i Slave 0 exists.
A1H	AS-i slave with the address to be modified was not found on the AS-Interface.
A2H	AS-i Slave 0 exists.
A3H	An AS-i slave with the newly assigned address already exists on the AS-Interface.
A4H	The slave address cannot be deleted.
A5H	The slave address cannot be set.
A6H	The slave address cannot be stored.
F8H	Command number is unknown or command interpreter incorrect.
F9H	EEPROM error

3.6.1 Set_Permanent_Parameter

Meaning

With this call, a parameter value for the specified slave is transferred to the CP 242-8. The value is saved permanently as a configured value.

The parameter is **not** transferred immediately to the AS-i slave by the CP 242-8. The parameter value is only transferred after the power supply of the PLC is turned on and the AS-i slave is activated.

Structure of the Command Buffer

Bank	Byte	Meaning			
		Bit 7	Bit 4	Bit 3	Bit 0
2	0	Command number: 00H			
2	1	AS-i slave address			
2	2	irrelevant		Parameter	

Structure of the Response Buffer

Bank	Byte	Meaning
2	0	Echo of the command number: 00H
2	1	Command status

3.6.2 Get_Permanent_Parameter

Meaning

With this call, a slave-specific parameter value stored on the EEPROM of the CP 242-8 is read.

Structure of the Command Buffer

Bank	Byte	Meaning
2	0	Command number: 01H
2	1	AS-i slave address

Structure of the Response Buffer

Bank	Byte	Meaning			
		Bit 7	Bit 4	Bit 3	Bit 0
2	0	Echo of the command number: 01H			
2	1	Command status			
2	2	irrelevant		Parameter echo	

3.6.3 Write_Parameter

Meaning of the Command

The AS-i parameter value transferred with the command is passed on to the addressed AS-i slave.

The parameter is stored only **temporarily** on the CP 242-8. After turning the power for the CP 242-8 off and then on again, the parameters are set to the values configured on the CP 242-8.

The AS-i slave transfers the current parameter value in the response. This can deviate from the value that has just been written according to the AS-i master specification (/2/). The slave response is entered in the parameter echo field.

For additional information about the use of this job, refer to the detailed explanations in /1/ and /2/.

Structure of the Command Buffer

Bank	Byte	Meaning			
		Bit 7	Bit 4	Bit 3	Bit 0
2	0	Command number: 02H			
2	1	AS-i slave address			
2	2	irrelevant		Parameter	

Structure of the Response Buffer

Bank	Byte	Meaning			
		Bit 7	Bit 4	Bit 3	Bit 0
2	0	Echo of the command number: 02H			
2	1	Command status			
2	2	irrelevant		Parameter echo	

3.6.4 Read_Parameter

Meaning

This call returns the current parameter value (actual parameter) of a slave.

Structure of the Command Buffer

Bank	Byte	Meaning
2	0	Command number: 03H
2	1	AS-i slave address

Structure of the Response Buffer

Bank	Byte	Meaning			
		Bit 7	Bit 4	Bit 3	Bit 0
2	0	Echo of the command number: 03H			
2	1	Command status			
2	2	irrelevant		Parameter echo	

3.6.5 Store_Actual_Parameters

Meaning

This call overwrites the permanently stored configured parameters with the actual parameters, in other words the parameters are reconfigured.

Structure of the Command Buffer

Bank	Byte	Meaning
2	0	Command number: 04H

Structure of the Response Buffer

Bank	Byte	Meaning
2	0	Echo of the command number: 04H
2	1	Command status

3.6.6 Set_Permanent_Configuration

Meaning

This call configures the I/O configuration data and the ID code for the addressed AS-i slave. The data are stored permanently on the CP 242-8.

Note

When this command is executed, the CP 242-8 changes to the offline phase and then returns to normal operation (complete restart on the CP 242-8 and reset on all AS-i slaves).

Structure of the Command Buffer

Bank	Byte	Meaning			
		Bit 7	Bit 4	Bit 3	Bit 0
2	0	Command number: 05H			
2	1	AS-i slave address			
2	2	ID code		I/O configuration	

Structure of the Response Buffer

Bank	Byte	Meaning
2	0	Echo of the command number: 05H
2	1	Command status

3.6.7 Get_Permanent_Configuration

Meaning

This call returns the desired configuration data of an addressed slave stored permanently in the EEPROM (I/O configuration data and the ID codes).

Structure of the Command Buffer

Bank	Byte	Meaning
2	0	Command number: 06H
2	1	AS-i slave address

Structure of the Response Buffer

Bank	Byte	Meaning			
		Bit 7	Bit 4	Bit 3	Bit 0
2	0	Echo of the command number: 06H			
2	1	Command status			
2	2	ID code		I/O configuration	

3.6.8 Store_Actual_Configuration

Meaning of the Command

This call stores the actual I/O configuration data and actual ID codes of all AS-i slaves permanently in the EEPROM of the CP 242-8 as desired configuration data. The list of activated AS-i slaves (LAS) is adopted in the list of permanent AS-i slaves (LPS).

Note

When executing this command, the CP 242-8 changes to the offline phase and then switches to the normal mode (complete restart on the CP 242-8).

The call is **not** executed in the protected mode.

Structure of the Command Buffer

Bank	Byte	Meaning
2	0	Command number: 07H

Structure of the Response Buffer

Bank	Byte	Meaning
2	0	Echo of the command number: 07H
2	1	Command status

3.6.9 Read_Actual_Configuration

Meaning of the Command

With this call, the (actual) I/O configuration data and (actual) ID codes of an addressed AS-i slave detected on the AS-Interface are returned.

Structure of the Command Buffer

Bank	Byte	Meaning
2	0	Command number: 08H
2	1	AS-i slave address

Structure of the Response Buffer

Bank	Byte	Meaning			
		Bit 7	Bit 4	Bit 3	Bit 0
2	0	Echo of the command number: 08H			
2	1	Command status			
2	2	ID code		I/O configuration	

3.6.10 Set_LPS

Meaning

With this call, the list of configured AS-i slaves is transferred for permanent storage in the EEPROM.

Note

When this command is executed, the CP 242-8 changes to the offline phase and then returns to normal operation (complete restart on the CP 242-8 with reset on all slaves).

This call is **not** executed in the protected mode.

Structure of the Command Buffer

Bank	Byte	Meaning							
		Bit 7	Bit 6	Bit 5	Bit 4	Bit 3	Bit 2	Bit 1	Bit 0
2	0	09H							
2	1	00H							
2	2	Slave 0	Slave 1	Slave 2	Slave 3	Slave 4	Slave 5	Slave 6	Slave 7
2	3	Slave 8	Slave 9	slave 10	Slave 11	Slave 12	Slave 13	Slave 14	Slave 15
2	4	Slave 16	Slave 17	Slave 18	Slave 19	Slave 20	Slave 21	Slave 22	Slave 23
2	5	Slave 24	Slave 25	Slave 26	Slave 27	Slave 28	Slave 29	slave 30	Slave 31

Structure of the Response Buffer

Bank	Byte	Meaning
2	0	Echo of the command number: 09H
2	1	Command status

3.6.11 Set_Offline_Mode

Meaning

This call switches between the online and offline mode.

The OFFLINE bit is **not** permanently stored, in other words, during the startup/restart the bit is set to ONLINE again.

In the offline mode, the CP 242-8 only processes jobs from the user. There is no cyclic data exchange.

The **online mode** is the normal situation for the CP 242-8. Here, the following jobs are processed cyclically:

- During the data exchange phase, the fields of the output data are transferred to the slave outputs for all slaves in the LAS. The addressed slaves transfer the values of the slave inputs to the master when the transfer was free of errors.
- This is followed by the inclusion phase in which there is a search for the existing AS-i slaves and newly added AS-i slaves are entered in the LDS or LAS.
- In the management phase, jobs from the user such as writing parameters are executed.

Structure of the Command Buffer

Bank	Byte	Meaning		
		Bit 7	Bit 1	Bit 0
2	0	Command number: 0AH		
2	1	reserved		Mode (0=online 1=offline)

Structure of the Response Buffer

Bank	Byte	Meaning
2	0	Echo of the command number: 0AH
2	1	Command status

3.6.12 Select Autoprogramming

Meaning

With this call, the automatic address programming function can be enabled or disabled.

The **AUTO_ADDR_ENABLE** bit is stored permanently.

Structure of the Command Buffer

Bank	Byte	Meaning		
		Bit 7	Bit 1	Bit 0
2	0	Command number: 0BH		
2	1	reserved		Value for AUTO_ADDR_ENABLE 1=Enable automatic address programming 0=Disable automatic address programming

Structure of the Response Buffer

Bank	Byte	Meaning
2	0	Echo of the command number: 0BH
2	1	Command status

3.6.13 Set_Operation_Mode

Meaning of the Command

With this call, you can select between the configuration mode and the protected mode.

In the **protected mode**, only AS-i slaves are activated that are entered in the LPS and whose expected and actual configurations match, in other words when the I/O configuration and ID codes of the detected AS-i slaves are identical to the configured values.

In the **configuration mode**, all detected AS-i slaves (except for slave address "0") are activated. This also applies to AS-i slaves in which there are differences between the expected and actual configuration. The "OPERATION MODE" bit is saved **permanently** in the EEPROM, i.e. it is retained following a startup/restart.

With a change from the configuration mode to the protected mode, the CP 242-8 is restarted (change to the offline phase followed by a change to the online mode).

Note

If an AS-i slave with the address "0" is connected, the CP 242-8 cannot switch from the configuration mode to the protected mode.

Structure of the Command Buffer

Bank	Byte	Meaning
2	0	Command number: 0CH
2	1	Mode protected mode: 00H configuration mode: 01H

Structure of the Response Buffer

Bank	Byte	Meaning
2	0	Echo of the command number: 0CH
2	1	Command status

3.6.14 Change_Slave_Address

Meaning of the Command

With this call, the address of an AS-i slave can be modified.

This call is mainly used to add a new AS-i slave with the default address "0" to the AS-Interface. In this case, there is an address change from "slave address old" = 0 to "slave address new".

This change can only be made when the following conditions are fulfilled:

1. An AS-i slave with "slave address old" exists.
2.  be connected at the same time.
3. The "slave address new" must have a valid value.
4. An AS-i slave with "slave address new" must not exist.

Note: When the slave address is changed, the AS-i slave is not reset, in other words the output data of the AS-i slave are retained until new data are received at the new address.

Structure of the Command Buffer

Bank	Byte	Meaning
2	0	Command number: 0DH
2	1	Slave address old
2	2	Slave address new

Structure of the Response Buffer

Bank	Byte	Meaning
2	0	Echo of the command number: 0DH
2	1	Command status

3.6.15 Read Slave Status

Meaning

With this call, the status register of the addressed AS-i slave can be read out.

The flags of the status register have the following significance:

S0: Address volatile

This flag is set,

– when the internal slave routine for permanent storage of the slave address is active. This can take up to 15 ms and must not be interrupted by a further addressing call.

– when the internal slave address comparison recognizes that the stored address is not the same as the entry in the address register.

S1: Parity error detected

This flag is set when the slave has recognized a parity error in a received frame since the last “read and delete status” job.

S2: End bit error detected

This flag is set when the slave has recognized an end bit error in a received frame since the last “read and delete status” job.

S3: Read error non-volatile memory

This flag is set when a read error has occurred when reading the non-volatile memory during a reset.

Structure of the Command Buffer

Bank	Byte	Meaning
2	0	Command number: 0FH
2	1	AS-i slave address

Structure of the Response Buffer

Bank	Byte	Meaning				
		Bit 7	Bit 4	Bit 3	Bit 2	Bit 1
2	0	Echo of the command number: 0FH				
2	1	Command status				
2	2	reserved	S 3	S 2	S 1	S 0

3.6.16 Read Lists and Flags (Get_LPS, Get_LAS, Get_LDS, Get_Flags)

Meaning

With this call, the following entries are read out of the AS-i master CP 242-8:

- The list of active AS-i slaves (LAS)
- The list of detected AS-i slaves (LDS)
- The list of permanent AS-i slaves (LPS)
- The flags according to the AS-i specification.

Structure of the Command Buffer

Bank	Byte	Meaning
2	0	Command number: 10H

Structure of the Response Buffer

Bank	Byte	Meaning							
		Bit 7	Bit 6	Bit 5	Bit 4	Bit 3	Bit 2	Bit 1	Bit 0
2	0	10H							
2	1	Command status							
2	2	LAS slave 0	LAS slave 1	LAS slave 2	LAS slave 3	LAS slave 4	LAS slave 5	LAS slave 6	LAS slave 7
2	3	LAS slave 8	LAS slave 9	LAS slave 10	LAS slave 11	LAS slave 12	LAS slave 13	LAS slave 14	LAS slave 15
2	4	LAS slave 16	LAS slave 17	LAS slave 18	LAS slave 19	LAS slave 20	LAS slave 21	LAS slave 22	LAS slave 23
2	5	LAS slave 24	LAS slave 25	LAS slave 26	LAS slave 27	LAS slave 28	LAS slave 29	LAS slave 30	LAS slave 31
2	6	LDS slave 0	LDS slave 1	LDS slave 2	LDS slave 3	LDS slave 4	LDS slave 5	LDS slave 6	LDS slave 7
2	7	LDS slave 8	LDS slave 9	LDS slave 10	LDS slave 11	LDS slave 12	LDS slave 13	LDS slave 14	LDS slave 15
2	8	LDS slave 16	LDS slave 17	LDS slave 18	LDS slave 19	LDS slave 20	LDS slave 21	LDS slave 22	LDS slave 23
2	9	LDS slave 24	LDS slave 25	LDS slave 26	LDS slave 27	LDS slave 28	LDS slave 29	LDS slave 30	LDS slave 31
2	10	LPS slave 0	LPS slave 1	LPS slave 2	LPS slave 3	LPS slave 4	LPS slave 5	LPS slave 6	LPS slave 7

Bank	Byte	Meaning							
		Bit 7	Bit 6	Bit 5	Bit 4	Bit 3	Bit 2	Bit 1	Bit 0
2	11	LPS slave 8	LPS slave 9	LPS slave 10	LPS slave 11	LPS slave 12	LPS slave 13	LPS slave 14	LPS slave 15
2	12	LPS slave 16	LPS slave 17	LPS slave 18	LPS slave 19	LPS slave 20	LPS slave 21	LPS slave 22	LPS slave 23
2	13	LPS slave 24	LPS slave 25	LPS slave 26	LPS slave 27	LPS slave 28	LPS slave 29	LPS slave 30	LPS slave 31
2	14	Flag 1							
2	15	Flag 2							

Flag 1

Flag 2

Bit Number	Meaning	Bit Number	Meaning
0	OFFLINE_READY	0	OFFLINE
1	APF	1	reserved
2	NORMAL_MODE	2	EEPROM_OK
3	CONFIG_MODE	3	AUTO_ADDR_ENABLE
4	AUTO_ADDR_AVAIL	4	reserved
5	AUTO_ADDR_ASSIGN	5	reserved
6	LDS_0	6	reserved
7	CONFIG_OK	7	reserved

Meaning of the Flags

OFFLINE_READY	The flag is set when the offline phase is active.
APF	This flag is set when the voltage on the AS-i cable is too low.
NORMAL_MODE	This flag is set when the CP 242-8 is in the normal mode.
CONFIG_MODE	The flag is set in the configuration mode and reset in the protected mode.
AUTO_ADDR_AVAIL	This flag is set when the automatic address programming can be executed (in other words exactly <u>one</u> slave is currently out of operation).
AUTO_ADDR_ASSIGN	This flag is set when the automatic address programming is possible (in other words AUTO_ADDR_ENABLE = 1 <u>and</u> there is or was no "incorrect" slave connected to the AS-i cable).
LDS_0	This flag is set when a slave exists with address 0.
CONFIG_OK	This flag is set when the desired (configured) and actual configuration match.
OFFLINE	This flag is set when the CP is to change to the OFFLINE mode or is already in this mode.
EEPROM_OK	This flag is set when the test of the internal EEPROM did not detect any errors.
AUTO_ADDR_ENABLE	This flag indicates whether the automatic address programming is enabled (BIT = 1) or disabled (BIT = 0) by the user.

3.6.17 Read Total Configuration

Meaning

With this command, the following data is read from the CP 242-8:

- The list of active slaves (LAS). This indicates which of the connected slaves are activated.
- The current configuration data of the connected slaves (I/O configuration and ID code).
- The current parameters of the slaves (actual parameters).
- The current flags.

This command can, for example, be used to find out the configuration of the stations connected to the AS-i cable after installation. The configuration data read in can, if necessary, be modified and saved on the CP 242-8 as the expected configuration using the command 'Configure Total System' (see Section 3.6.18).

Structure of the Command Buffer

Bank	Byte	Meaning
2	0	Command number: 19H

Structure of the Response Buffer

Bank	Byte	Meaning							
		Bit 7	Bit 6	Bit 5	Bit 4	Bit 3	Bit 2	Bit 1	Bit 0
2	0	19H							
2	1	Command status							
2	2	irrelevant	LAS slave 1	LAS slave 2	LAS slave 3	LAS slave 4	LAS slave 5	LAS slave 6	LAS slave 7
2	3	LAS slave 8	LAS slave 9	LAS slave 10	LAS slave 11	LAS slave 12	LAS slave 13	LAS slave 14	LAS slave 15
2	4	LAS slave 16	LAS slave 17	LAS slave 18	LAS slave 19	LAS slave 20	LAS slave 21	LAS slave 22	LAS slave 23
2	5	LAS slave 24	LAS slave 25	LAS slave 26	LAS slave 27	LAS slave 28	LAS slave 29	LAS slave 30	LAS slave 31
2	6	ID_CODE slave 0				I/O configuration slave 0			
2	7	ID_CODE slave 1				I/O configuration slave 1			
2	8	ID_CODE slave 2				I/O configuration slave 2			
2	9	ID_CODE slave 3				I/O configuration slave 3			
2	10	ID_CODE slave 4				I/O configuration slave 4			
2	11	ID_CODE slave 5				I/O configuration slave 5			
2	12	ID_CODE slave 6				I/O configuration slave 6			
2	13	ID_CODE slave 7				I/O configuration slave 7			

2	14	ID_CODE slave 8	I/O configuration slave 8
2	15	ID_CODE slave 9	I/O configuration slave 9
3	0	ID_CODE slave 10	I/O configuration slave 10
3	1	ID_CODE slave 11	I/O configuration slave 11
3	2	ID_CODE slave 12	I/O configuration slave 12
3	3	ID_CODE slave 13	I/O configuration slave 13
3	4	ID_CODE slave 14	I/O configuration slave 14
3	5	ID_CODE slave 15	I/O configuration slave 15
3	6	ID_CODE slave 16	I/O configuration slave 16
3	7	ID_CODE slave 17	I/O configuration slave 17
3	8	ID_CODE slave 18	I/O configuration slave 18
3	9	ID_CODE slave 19	I/O configuration slave 19
3	10	ID_CODE slave 20	I/O configuration slave 20
3	11	ID_CODE slave 21	I/O configuration slave 21
3	12	ID_CODE slave 22	I/O configuration slave 22
3	13	ID_CODE slave 23	I/O configuration slave 23
3	14	ID_CODE slave 24	I/O configuration slave 24
3	15	ID_CODE slave 25	I/O configuration slave 25
4	0	ID_CODE slave 26	I/O configuration slave 26
4	1	ID_CODE slave 27	I/O configuration slave 27
4	2	ID_CODE slave 28	I/O configuration slave 28
4	3	ID_CODE slave 29	I/O configuration slave 29
4	4	ID_CODE slave 30	I/O configuration slave 30
4	5	ID_CODE slave 31	I/O configuration slave 31
4	6	irrelevant	Parameter slave 1
4	7	Parameter slave 2	Parameter slave 3
4	8	Parameter slave 4	Parameter slave 5
4	9	Parameter slave 6	Parameter slave 7
4	10	Parameter slave 8	Parameter slave 9
4	11	Parameter slave 10	Parameter slave 11
4	12	Parameter slave 12	Parameter slave 13
4	13	Parameter slave 14	Parameter slave 15
4	14	Parameter slave 16	Parameter slave 17
4	15	Parameter slave 18	Parameter slave 19
5	0	Parameter slave 20	Parameter slave 21
5	1	Parameter slave 22	Parameter slave 23
5	2	Parameter slave 24	Parameter slave 25
5	3	Parameter slave 26	Parameter slave 27
5	4	Parameter slave 28	Parameter slave 29
5	5	Parameter slave 30	Parameter slave 31
5	6	Flag 1	
5	7	Flag 2	

The meaning of the flags is the same as for the read lists and flags job (see Section 3.6.16).

3.6.18 Configure Total System

Meaning

With this call, the desired total configuration is transferred to the CP 242-8 and saved on the CP 242-8 as the desired configuration. This configures the CP 242-8.

The following data are transferred:

- The list of configured slaves specifying the slaves that can be activated by the CP 242-8 in the protected mode.
- The list of configuration data specifying the ID codes and I/O configurations the AS-i slaves must have.
- The list of parameters saved in non-volatile memory on the CP 242-8. This is transferred to the AS-i slaves during the startup of the CP 242-8.
- The flags that determine the mode of the CP 242-8 after startup (in other words after the CP 242-8 has been synchronized).

Structure of the Command Buffer

Bank	Byte	Meaning							
		Bit 7	Bit 6	Bit 5	Bit 4	Bit 3	Bit 2	Bit 1	Bit 0
2	0	1AH							
2	1	reserved							
2	2	irrelevant	LPS slave 1	LPS slave 2	LPS slave 3	LPS slave 4	LPS slave 5	LPS slave 6	LPS slave 7
2	3	LPS slave 8	LPS slave 9	LPS slave 10	LPS slave 11	LPS slave 12	LPS slave 13	LPS slave 14	LPS slave 15
2	4	LPS slave 16	LPS slave 17	LPS slave 18	LPS slave 19	LPS slave 20	LPS slave 21	LPS slave 22	LPS slave 23
2	5	LPS slave 24	LPS slave 25	LPS slave 26	LPS slave 27	LPS slave 28	LPS slave 29	LPS slave 30	LPS slave 31
2	6	irrelevant				irrelevant			
2	7	ID_CODE slave 1				I/O configuration slave 1			
2	8	ID_CODE slave 2				I/O configuration slave 2			
2	9	ID_CODE slave 3				I/O configuration slave 3			
2	10	ID_CODE slave 4				I/O configuration slave 4			
2	11	ID_CODE slave 5				I/O configuration slave 5			
2	12	ID_CODE slave 6				I/O configuration slave 6			
2	13	ID_CODE slave 7				I/O configuration slave 7			
2	14	ID_CODE slave 8				I/O configuration slave 8			
2	15	ID_CODE slave 9				I/O configuration slave 9			
3	0	ID_CODE slave 10				I/O configuration slave 10			
3	1	ID_CODE slave 11				I/O configuration slave 11			
3	2	ID_CODE slave 12				I/O configuration slave 12			
3	3	ID_CODE slave 13				I/O configuration slave 13			
3	4	ID_CODE slave 14				I/O configuration slave 14			
3	5	ID_CODE slave 15				I/O configuration slave 15			
3	6	ID_CODE slave 16				I/O configuration slave 16			
3	7	ID_CODE slave 17				I/O configuration slave 17			

3	8	ID_CODE slave 18	I/O configuration slave 18
3	9	ID_CODE slave 19	I/O configuration slave 19
3	10	ID_CODE slave 20	I/O configuration slave 20
3	11	ID_CODE slave 21	I/O configuration slave 21
3	12	ID_CODE slave 22	I/O configuration slave 22
3	13	ID_CODE slave 23	I/O configuration slave 23
3	14	ID_CODE slave 24	I/O configuration slave 24
3	15	ID_CODE slave 25	I/O configuration slave 25
4	0	ID_CODE slave 26	I/O configuration slave
4	1	ID_CODE slave 27	I/O configuration slave
4	2	ID_CODE slave 28	I/O configuration slave
4	3	ID_CODE slave 29	I/O configuration slave
4	4	ID_CODE slave 30	I/O configuration slave
4	5	ID_CODE slave 31	I/O configuration slave
4	6	irrelevant	Parameter slave 1
4	7	Parameter slave 2	Parameter slave 3
4	8	Parameter slave 4	Parameter slave 5
4	9	Parameter slave 6	Parameter slave 7
4	10	Parameter slave 8	Parameter slave 9
4	11	Parameter slave 10	Parameter slave 11
4	12	Parameter slave 12	Parameter slave 13
4	13	Parameter slave 14	Parameter slave 15
4	14	Parameter slave 16	Parameter slave 17
4	15	Parameter slave 18	Parameter slave 19
5	0	Parameter slave 20	Parameter slave 21
5	1	Parameter slave 22	Parameter slave 23
5	2	Parameter slave 24	Parameter slave 25
5	3	Parameter slave 26	Parameter slave 27
5	4	Parameter slave 28	Parameter slave 29
5	5	Parameter slave 30	Parameter slave 31
5	6	Flag 1	
5	7	Flag 2	

Structure of the Response Buffer

Bank	Byte	Meaning
2	0	Echo of the command number: 1AH
2	1	Command status

Flag 1**Flag 2**

Name	Bit Number		Name	Bit Number
RESERVED	0		RESERVED	0
RESERVED	1		RESERVED	1
RESERVED	2		RESERVED	2
CONFIG_MODE	3		AUTO_ADDR_ENABLE	3
RESERVED	4		RESERVED	4
RESERVED	5		RESERVED	5
RESERVED	6		RESERVED	6
RESERVED	7		RESERVED	7

Only the gray shaded flags can be modified.

CONFIG_MODE	The entry '0' means that the CP 242-8 changes to the protected mode after executing the command. The entry '1' means that the CP continues in the configuration mode.
AUTO_ADDR_ENABLE	'0' means that the automatic address programming is disabled, '1' means that the automatic address programming is enabled.

The values of the other flags are irrelevant for the "configure total system" command.

3.6.19 Write Parameter List

Meaning

With this command, the parameters for all slaves are transferred to the CP 242-8. The CP 242-8 transfers **only** the parameters **that have changed, in other words that deviate from the current actual parameters** to the AS-i slaves.

Structure of the Command Buffer

Bank	Byte	Meaning							
		Bit 7	Bit 6	Bit 5	Bit 4	Bit 3	Bit 2	Bit 1	Bit 0
2	0	1CH							
2	1	00H							
2	2	irrelevant				Parameter slave 1			
2	3	Parameter slave 2				Parameter slave 3			
2	4	Parameter slave 4				Parameter slave 5			
2	5	Parameter slave 6				Parameter slave 7			
2	6	Parameter slave 8				Parameter slave 9			
2	7	Parameter slave 10				Parameter slave 11			
2	8	Parameter slave 12				Parameter slave 13			
2	9	Parameter slave 14				Parameter slave 15			
2	10	Parameter slave 16				Parameter slave 17			
2	11	Parameter slave 18				Parameter slave 19			
2	12	Parameter slave 20				Parameter slave 21			
2	13	Parameter slave 22				Parameter slave 23			
2	14	Parameter slave 24				Parameter slave 25			
2	15	Parameter slave 26				Parameter slave 27			
3	0	Parameter slave 28				Parameter slave 29			
3	1	Parameter slave 30				Parameter slave 31			

Structure of the Response Buffer

Bank	Byte	Meaning
1	1	Echo of the command number: 1CH
2	2	Command status

3.6.20 Read Parameter Echo List

Meaning

When the parameters are transferred to the AS-i slaves, they return “echo values” as the response. The read parameter echo list call reads out the echo values of all AS-i slaves.

Structure of the Command Buffer

Bank	Byte	Meaning							
		Bit 7	Bit 6	Bit 5	Bit 4	Bit 3	Bit 2	Bit 1	Bit 0
2	0	Command number: 13H							

Structure of the Response Buffer

Bank	Byte	Meaning	
2	0	13H	
2	1	Command status	
2	2	irrelevant	Parameter echo slave 1
2	3	Parameter echo slave 2	Parameter echo slave 3
2	4	Parameter echo slave 4	Parameter echo slave 5
2	5	Parameter echo slave 6	Parameter echo slave 7
2	6	Parameter echo slave 8	Parameter echo slave 9
2	7	Parameter echo slave 10	Parameter echo slave 11
2	8	Parameter echo slave 12	Parameter echo slave 13
2	9	Parameter echo slave 14	Parameter echo slave 15
2	10	Parameter echo slave 16	Parameter echo slave 17
2	11	Parameter echo slave 18	Parameter echo slave 19
2	12	Parameter echo slave 20	Parameter echo slave 21
2	13	Parameter echo slave 22	Parameter echo slave 23
2	14	Parameter echo slave 24	Parameter echo slave 25
2	15	Parameter echo slave 26	Parameter echo slave 27
3	0	Parameter echo slave 28	Parameter echo slave 29
3	1	Parameter echo slave 30	Parameter echo slave 31

3.6.21 Read Version ID

Meaning

With this call, the version ID of the CP 242-8 firmware is read out.

Structure of the Command Buffer

Bank	Byte	Meaning
2	0	Command number: 14H

The response of the CP 242-8 contains the name and the firmware version number of the CP 242-8 in the form shown below:

Structure of the Response Buffer

Bank	Byte	Meaning
2	0	14H
2	1	Command status
2	2	C
2	3	P
2	4	
2	5	2
2	6	4
2	7	2
2	8	–
2	9	8
2	10	
2	11	V
2	12	x
2	13	.
2	14	y
2	15	y

x.y.y stands for the current version number of the CP 242-8 firmware.

3.6.22 Read and Delete Slave Status

Meaning

With this call, the status of an AS-i slave is read out and at the same time the status register of the AS-i slave is deleted.

The flags of the status register have the following significance:

S0: Address volatile

This flag is set

– when the internal slave routine for permanent storage of the slave address is active. This can take up to 15 ms and must not be interrupted by a further addressing call.

– when the internal slave address comparison recognizes that the stored address is not the same as the entry in the address register.

S1: Parity error detected

This flag is set when the AS-i slave has recognized a parity error in a received frame since the last “read and delete status” job.

S2: End bit error detected

This flag is set when the AS-i slave has recognized an end bit error in a received frame since the last “read and delete status” job.

S3: Read error non-volatile memory

This flag is set when a read error has occurred when reading the non-volatile memory.

Structure of the Command Buffer

Bank	Byte	Meaning
2	0	Command number: 16H
2	1	AS-i slave address

Structure of the Response Buffer

Bank	Byte	Meaning				
		Bit 7	Bit 4	Bit 3	Bit 2	Bit 1
2	0	16H				
2	1	Command status				
2	2	reserved	S 3	S 2	S 1	S 0

3.6.23 Read Slave ID

Meaning

With this call, the ID code of an AS-i slave can be read out directly over the AS-i cable. The call is intended for diagnostic purposes and is not required in the normal master mode.

Structure of the Command Buffer

Bank	Byte	Meaning
2	0	Command number: 17H
2	1	AS-i slave address

Structure of the Response Buffer

Bank	Byte	Meaning			
		Bit 7	Bit 4	Bit 3	Bit 0
2	0	Echo of the command number: 17H			
2	1	Command status			
2	2	reserved		Slave ID	

3.6.24 Read Slave I/O

Meaning

With this call, the I/O configuration of an AS-i slave can be read out directly over the AS-i cable. The call is intended for diagnostic purposes and is not required in the normal master mode.

Structure of the Command Buffer

Bank	Byte	Meaning
2	0	Command number: 18
2	1	AS-i slave address

Structure of the Response Buffer

Bank	Byte	Meaning			
		Bit 7	Bit 4	Bit 3	Bit 0
2	0	Echo of the command number: 18H			
2	1	Command status			
2	2	reserved		Slave I/O	

3.6.25 Read Data and Delta List

Meaning

With this call, the AS-i error bits, the input data of the AS-i slaves and the delta list can be read out consistently.

Structure of the Command Buffer

Bank	Byte	Meaning
2	0	Command number: 1DH

Structure of the Response Buffer

Bank	Byte	Meaning							
		Bit 7	Bit 6	Bit 5	Bit 4	Bit 3	Bit 2	Bit 1	Bit 0
2	0	1DH							
2	1	Command status							
2	2	APF	CER	0	0	Data slave 1			
2	3	Data slave 2				Data slave 3			
2	4	Data slave 4				Data slave 5			
2	5	Data slave 6				Data slave 7			
2	6	Data slave 8				Data slave 9			
2	7	Data slave 10				Data slave 11			
2	8	Data slave 12				Data slave 13			
2	9	Data slave 14				Data slave 15			
2	10	Data slave 16				Data slave 17			
2	11	Data slave 18				Data slave 19			
2	12	Data slave 20				Data slave 21			
2	13	Data slave 22				Data slave 13			
2	14	Data slave 24				Data slave 25			
2	15	Data slave 26				Data slave 27			
3	0	Data slave 28				Data slave 29			
3	1	Data slave 30				Data slave 31			
3	2	Delta slave 7	Delta slave 6	Delta slave 5	Delta slave 4	Delta slave 3	Delta slave 2	Delta slave 1	Delta slave 0
3	3	Delta slave 15	Delta slave 14	Delta slave 13	Delta slave 12	Delta slave 11	Delta slave 10	Delta slave 9	Delta slave 8
3	4	Delta slave 23	Delta slave 22	Delta slave 21	Delta slave 20	Delta slave 19	Delta slave 18	Delta slave 17	Delta slave 16
3	5	Delta slave 31	Delta slave 30	Delta slave 29	Delta slave 28	Delta slave 27	Delta slave 26	Delta slave 25	Delta slave 24

The meaning of the error bits APF and CER is the same as in the error register.



4

The CP 242-8 as PROFIBUS DP Slave

4.1	Transferring User Data between the DP Master and CP 242-8	4-2
4.2	Controlling Access with the DP Data Area	4-4
4.2.1	Byte-Consistent Data Transfer	4-5
4.2.2	Block-Consistent Data Transfer	4-7
4.3	DP Status Information	4-11
4.4	Configuring the CP 242-8 on the DP Master/Content of the Type File and the DDB File	4-13
4.5	Transmission Rate on PROFIBUS	4-16
4.6	PROFIBUS DP Control Commands	4-17
4.7	DP Slave Diagnostics	4-18
4.7.1	Station Status 1 to 3	4-19
4.7.2	PROFIBUS Address of the DP Master and Vendor ID	4-21
4.7.3	Structure of the Device-Related Diagnostic Information	4-21

4.1 Transferring User Data Between the DP Master and CP 242-8

The CP 242-8 is a DP slave

On PROFIBUS DP, the CP 242-8 behaves like a DP slave. This means that an S7-200 CPU can exchange data via the DP interface of the CP 242-8 with a PROFIBUS DP master.

Cyclic Access of the DP Master to Input and Output Data

The DP master accesses the CP 242-8 cyclically. During this access, it transfers output data to the CP 242-8 that are available in the user program of the S7-200 as input data.

The S7-200 user program, on the other hand, provides the CP 242-8 with output data that the DP master can read. In other words, these data are input data for the DP master.

Transferring Data from the DP Master to the CP 242-8 (Output Data of the DP Master/Input Data of the CP 242-8)

Depending on the configuration, the DP master transfers 2 to 64 (DP output) bytes to the CP 242-8 cyclically (see Section 4.4). This data is stored in bank 12 to bank 15 of the CP 242-8.

The user program of the S7-200 CPU can read this data and therefore evaluate the data coming from the DP master.

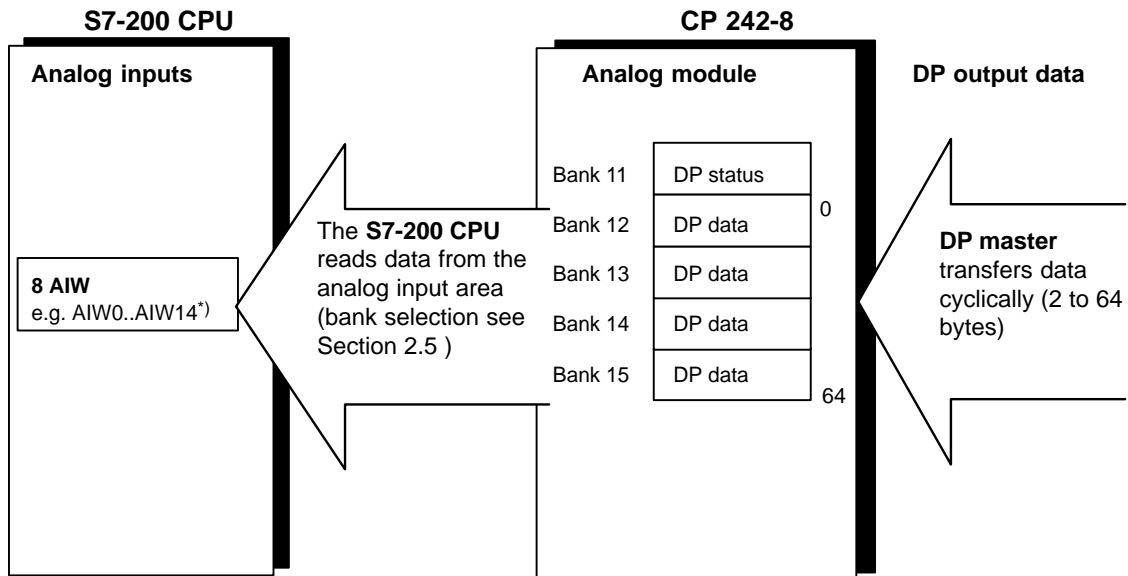

*) The address area depends on the slot of the CP 242-8 (see Section 2.2)

Figure 4-1

Transferring Data from the CP 242-8 to the DP Master (Input Data of the DP Master/Output Data of the CP 242-8)

In the other direction, depending on the configuration, the DP master reads 2 to 64 (DP input) bytes from the CP 242-8 cyclically (see Section 4.4).

This data is stored by the user program of the S7-200 in bank 12 to bank 15 of the CP 242-8.

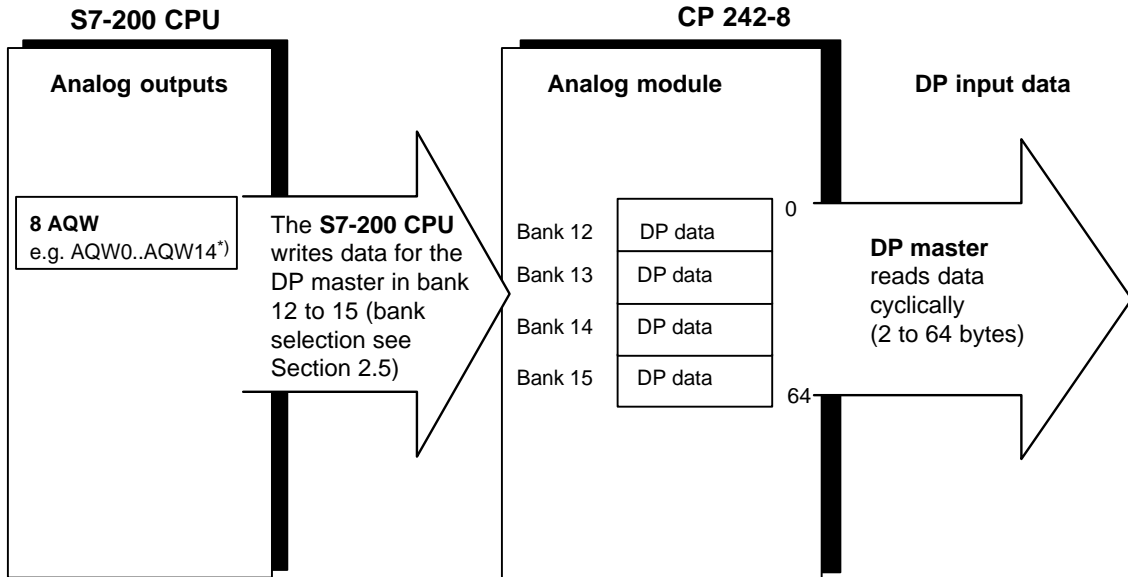

*) The address area depends on the slot of the CP 242-8 (see Section 2.2)

Figure 4-2

4.2 Controlling Access with the DP Data Area

The DP Master Configures Byte or Block Consistency

Access to the input and output data of the DP master by the CP 242-8 depends on whether byte or block consistency was selected in the configuration of the CP 242-8 for transfer by the DP master.

Byte consistency or block consistency is decided by the configuration of the DP master (see Section 4.4) and is signaled to the S7-200 user program by the DP_CONS bit in the status byte (see Section 2.3.3.).

Difference between Byte and Block Consistency

Byte-consistent transfer ensures that **byte** values are transferred correctly between the DP master and the CP 242-8. The bytes can contain, for example, the values of digital inputs and outputs, bit memory etc.

If, on the other hand, the data to be transferred contains values that are more than one byte long, for example analog values (2 bytes) or texts for an alphanumeric display, then block-consistent transfer must be set on the DP master.

Block-consistent transfer ensures the following:

- The S7-200 user program transfers its output data to the CP 242-8 as a block and reads the input data from the CP 242-8 as a block.
- A block is only transferred or accepted when all the required values were transferred to the CP 242-8. This is achieved with the CP 242-8 using a handshake mechanism as explained below.

4.2.1 Byte-Consistent Data Transfer

Principle

With byte-consistent transfer, the S7-200 user program can read the output data of the DP master or write the input data of the DP master without any additional measures providing the corresponding bank select bits are correctly set (see Section 2.5).

S7-200 Sample Program for Byte-Consistent Operation

This example applies to a CPU 212 plugged in directly beside a CP 242-8. The program transfers 64 bytes from the DP input buffer to the DP output buffer with byte consistency.

Table 4-1

STL	
NETWORK 1	//Startup processing
LD SM0.1	//if: first scan bit:
SI Q.7, 1	//PLC_RUN = 1
RI Q.0, 4	//select bank 0
NETWORK 2	//Transfer data with byte consistency
LDN I1.4	//if bit DP_CONS = 0 (=byte-consistent)
A I1.1	//and CP_READY is set
CALL 4	//then: SBR 4 "byte-consistent user data exchange"
NETWORK 3	//End of main program
MEND	
NETWORK 4	//Begin SBR "byte-consistent user data transfer"
SBR 4	
NETWORK 5	//Transfer the output data
SI Q1.2, 2	//select bank 12
BMW VW400, AQW0, 8	//transfer DP outputs
SI Q1.0, 1	//select bank 13
BMW VW416, AQW0, 8	//transfer DP outputs
SI Q1.1, 1	//select bank 14
RI Q1.0, 1	//select bank 14
BMW VW432, AQW0, 8	//transfer DP outputs
SI Q1.0, 1	//select bank 15
BMW VW448, AQW0, 8	//transfer DP outputs
RI Q1.0, 4	//select bank 0
NETWORK 6	//Transfer input data
SI Q1.2, 2	//select bank 12
BMW AIW0, VW400, 8	//transfer DP inputs
SI Q1.0, 1	//select bank 13
BMW AIW0, VW416, 8	//transfer DP inputs
SI Q1.1, 1	//select bank 14
RI Q1.0, 1	//select bank 14
BMW AIW0, VW432, 8	//transfer DP inputs
SI Q1.0, 1	//select bank 15
BMW AIW0, VW448, 8	//transfer DP inputs
RI Q1.0, 4	//select bank 0
NETWORK 7	//End SBR "byte-consistent user data transfer"
RET	

4.2.2 Block-Consistent Data Transfer

Handshake Mechanism to Control Updating of the Input and Output Data

- Acceptance of consistent input data in the user program of the S7-200 CPU:
The output data coming from the DP master (= input data for the S7-200 user program) are only updated for the S7-200 user program with block-consistent transfer when a handshake has taken place. This handshake is controlled by the DP_COM and DP_RESP bits.
If there is no handshake, the input data of the S7-200 user program remain unchanged.
- Output data are transferred consistently from the user program of the S7-200 CPU:
In the other direction, output data from the S7-200 user program intended for the DP master (= input data for the DP master) are only updated for the DP master after a handshake has taken place.

Control Byte: The DP_COM bit triggers the updating of the data (see Section 2.3.4)

By setting the "DP_COM" bit in the control byte to "1", you activate the updating of the input and output data.

Status Byte: The DP_RESP bit signals the processing status (see Section 2.3.3)

By querying the "DP_RESP" bit in the status byte, you can obtain information about the current update status.

For more detailed information about the structure of the user program and the interaction with the interface to the CP 242-8 refer to the command sequence described below.

Handshake Sequence for Block-Consistent Data Transfer

The diagram below shows the following:

- How to control the updating of the I/O data in the S7-200 user program
- How the CP 242-8 reacts to the control bit

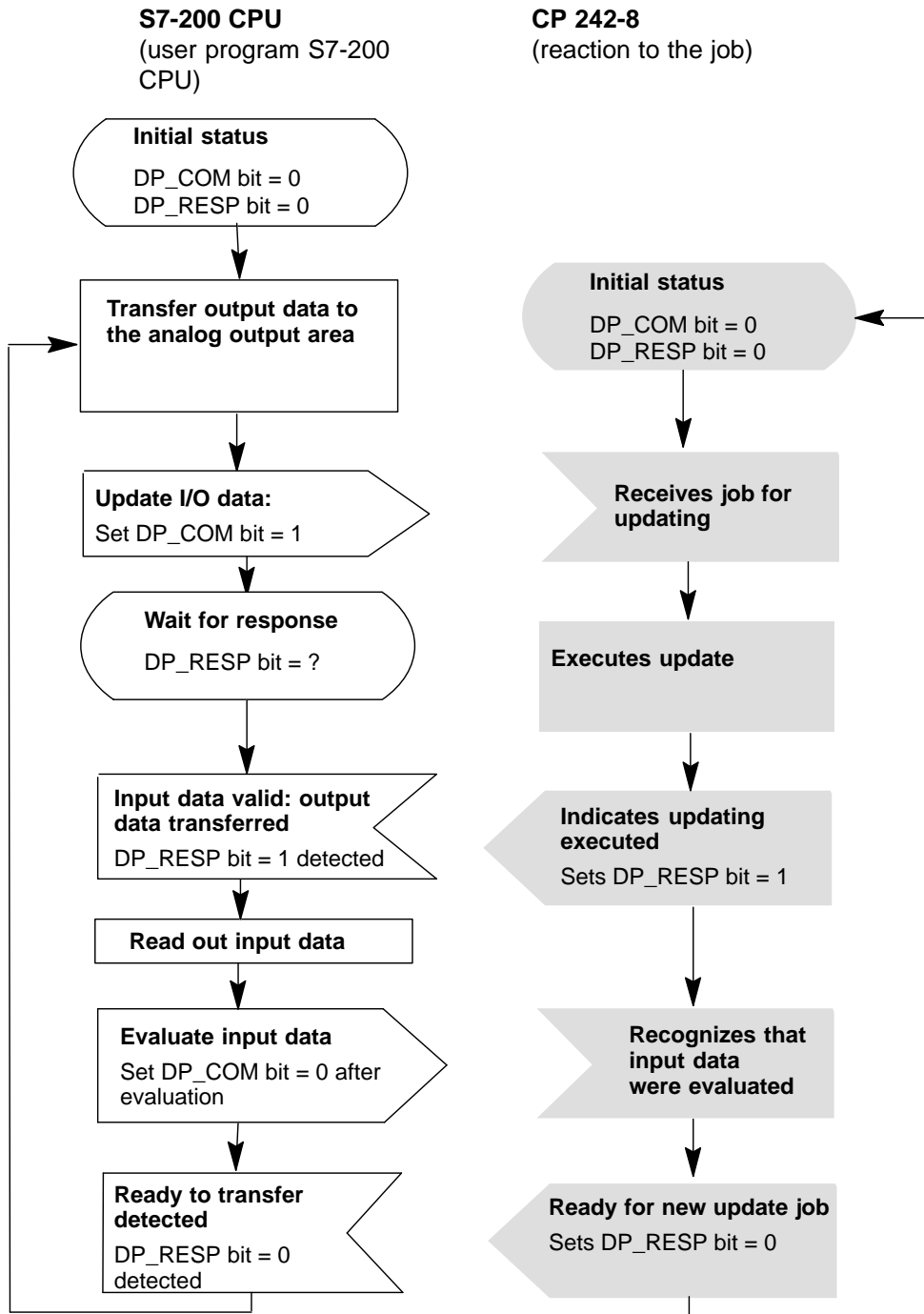

Figure 4-3

Note

An update started by the CP 242-8 is executed completely regardless of the state of the "DP_COM" bit.

The "DP_RESP" bit is only reset when the "DP_COM" bit is set to "0" by the user program.

Note

As long as the updating of the input and output data (handshake mechanism) is active, the user program of the S7-200 must not access the input and output data (bank 12 to 15) of the DP interface.

Example of Block-Consistent Data Transfer

The following example in STL applies to a CPU 212 with a CP 242-8 plugged in directly beside it. The program transfers 64 bytes from the DP input buffer to the DP output buffer with block consistency.

Table 4-2

STL	
NETWORK 1	//Startup processing
LD SM0.1	//if: first scan bit:
SI Q1.7, 1	//PLC_RUN = 1
RI Q1.0, 4	//select bank 0
NETWORK 2	//Transfer consistent data
LD I1.4	//if: DP_CONS = 1 (=block-consistent)
A I1.1	//and CP_READY set
CALL 5	//then: SBR 5 "block-consistent user data exchange"
NETWORK 3	//End of the main program
MEND	
NETWORK 4	//Begin SBR "block-consistent user data transfer"
SBR 5	
NETWORK 5	//Transfer output data
LDN I1.5	//if: DP_RESP bit = 0
AN Q1.5	//and DP_COM bit = 0
	//then:
SI Q1.2, 2	//select bank 12
BMW VW500, AQW0, 8	//transfer DP outputs
SI Q1.0, 1	//select bank 13
BMW VW516, AQW0, 8	//transfer DP outputs
SI Q1.1, 1	//select bank 14
RI Q1.0, 1	//select bank 14
BMW VW532, AQW0, 8	//transfer DP outputs
SI Q1.0, 1	//select bank 15
BMW VW548, AQW0, 8	//transfer DP outputs
RI Q1.0, 4	//select bank 0
SI Q1.5, 1	//start update (DP_COM = 1)
NETWORK 6	//Transfer input data
LD I1.5	//if: DP_RESP bit = 1
A Q1.5	//and DP_COM bit = 1
	//then:
SI Q1.2, 2	//select bank 12
BMW AIW0, VW500, 8	//transfer DP inputs
SI Q1.0, 1	//select bank 13
BMW AIW0, VW516, 8	//transfer DP inputs
SI Q1.1, 1	//select bank 14
RI Q1.0, 1	//select bank 14
BMW AIW0, VW532, 8	//transfer DP inputs
SI Q1.0, 1	//select bank 15
BMW AIW0, VW548, 8	//transfer DP inputs
RI Q1.0, 4	//select bank 0
RI Q1.5, 1	//end update (DP_COM = 0)
NETWORK 7	//End SBR "block-consistent user data transfer"
RET	

4.3 DP Status Information

DP Status Information in the Analog Module

DP status information is made available to the S7-200 user program in bank 11 of the analog module of the CP 242-8. With the appropriate bank-select command, the user program can access this status information.

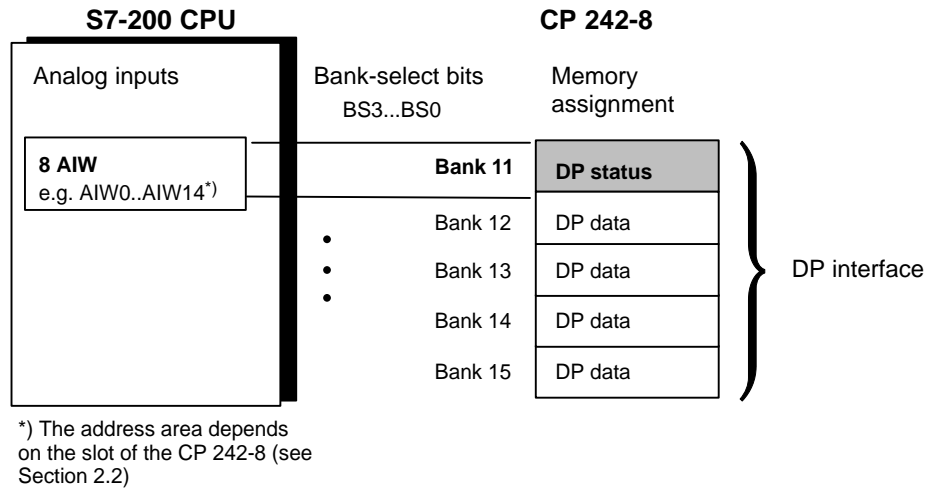

Figure 4-4

Meaning/Range of Values

The following DP status information can be evaluated by the S7-200 user program:

Table 4-3

Byte	Meaning/Range of Values
0	<p>DP status</p> <p>The content is identical to the value in the status byte of the CP 242-8 signaled by DP_State1 and DP_State 2 (see Section 2.3.3)</p> <p>The values of the bytes have the following significance:</p> <p>0: After turning on the CP 242-8, no communication has yet taken place between the DP master and the CP 242-8. (This includes parameter assignment/configuration).</p> <p>1: Parameter assignment or configuration error. Check the configuration of the DP master.</p> <p>2: Cyclic data exchange between the DP master and the CP 242-8 is active.</p> <p>3: Cyclic data exchange between the DP master and CP 242-8 is interrupted.</p>
1	<p>DP master address</p> <p>Address of the DP master that assigned parameters to/configured the CP 242-8.</p>
2	<p>DP slave address</p> <p>The PROFIBUS address set on the CP 242-8</p>
3	0
4	<p>Number of DP output bytes</p> <p>Specifies how many output bytes the DP master transfers to the CP 242-8. The number depends on the configuration and is between 2 and 64 bytes.</p>
5	<p>Number of DP input bytes</p> <p>Specifies how many input bytes the DP master reads from the CP 242-8. The number depends on the configuration and is between 2 and 64 bytes.</p>
6 to 15	0

4.4 Configuring the CP 242-8 in the DP Master/Content of the Type File and the DDB File

Meaning

To be able to configure the CP 242-8 in the DP master, you must import the type or DDB file into the configuration tool of the DP master. Refer to the information in the manual of the appropriate configuration tool.

Type file – on Diskette or per Modem

The type file **SI8049AX.200** contains all the necessary information about the CP 242-8 required by the configuration tool (for example STEP 7 or COM PROFIBUS).

The type file is shipped on diskette along with this manual and can also be downloaded via a modem from the Interface Center (**SSC**) Fürth at the telephone number ++49/911/737972.

DDB File – on Diskette or per Modem

The DDB file **SIEM8049.GSD** also contains the information about the CP 242-8 required by the configuration tool of the DP master.

You require the DDB file only when your DP master cannot process type files.

The DDB file is shipped on diskette along with this manual and can also be downloaded via a modem from the Interface Center (**SSC**) Fürth at the telephone number ++49/911/737972.

The DDB file can also be downloaded from the Internet at <http://www.ad.siemens.de> (under customer support/simatic/downloads...).

Parameter Assignment/Configuration Frame

If your DP master can process neither type nor DDB files, under some circumstances, you can enter the parameter assignment frame and configuration frame for the CP 242-8 when you configure the DP master. The structure of the parameter assignment and configuration frame for the CP 242-8 is explained in Appendix B.

BMP File (Bitmap)

To allow graphic representation of the CP 242-8, some configuration tools, for example STEP 7 V4 use bitmap files. These are also shipped on the accompanying diskette.

Configuration of the DP Interface by the DP Master

Depending on the number of data transferred between the DP master and the CP 242-8 and whether byte-consistent or block-consistent operation is required, the interface of the CP 242-8 can be configured in different ways by the DP master.

This means that only the number of input and output bytes actually required for data exchange with the CP 242-8 are occupied on the DP master.

The possible configurations are usually displayed for selection by the configuration tool of your DP master in a menu when you configure the CP 242-8. These are contained in the type file or DDB file of the CP 242-8.

The following tables list the configurations supported by the CP 242-8.

Table 4-4 Operation with Byte Consistency

Number of input/output bytes on the DP master		Consistency range
Number of output bytes	Number of input bytes	
2	2	Byte consistency
4	4	
8	8	
16	16	
32	32	
64	64	
4	16	
8	32	
16	64	
16	4	
32	8	
64	16	

Table 4-5 Operation with Block Consistency

Number of input/output bytes on the DP master		Consistency range
Number of output bytes	Number of input bytes	
2	2	Block consistency
4	4	
8	8	
16	16	
32	32	
64	64	
4	16	
8	32	
16	64	
16	4	
32	8	
64	16	

4.5 Transmission Rate on PROFIBUS

The CP 242-8 supports the following transmission rates on PROFIBUS DP:

9.6 Kbps	19.2 Kbps	45.45 Kbps	93.75 Kbps	187.5 Kbps
500 Kbps	1.5 Mbps	3 Mbps	6 Mbps	12 Mbps

4.6 PROFIBUS DP Control Commands

The CP 242-8 supports all the control commands contained in the PROFIBUS DP standard:

Table 4-6

Control command	Effect
FREEZE	The values of the DP input data received by the DP master from the CP 242-8 are frozen by the CP 242-8. The CP 242-8 updates this data once with each subsequent FREEZE.
UNFREEZE	The FREEZE command is canceled.
SYNC	The values of the DP output data passed on to the S7-200 user program by the CP 242-8 are frozen by the CP 242-8. The CP 242-8 updates this data once with each subsequent SYNC.
UNSYNC	The SYNC command is canceled.
CLEAR	The values of the DP output data transferred to the S7-200 user program by the CP 242-8 are set to '0' by the CP 242-8.

4.7 DP Slave Diagnostics

Meaning

The structure of DP slave diagnostics of the CP 242-8 is described below. DP slave diagnostic information is reported by the CP 242-8 when the PLC_RUN bit is set to 0 in the control byte of the CP 242-8. In this case, the CP 242-8 signals diagnostic information to the DP master. Using this mechanism, the DP master is informed of a STOP on the S7-200. As long as the PLC_RUN bit is set to 0, the CP 242-8 sends DP data with the value 0H to the DP master. When the S7-200 changes from "STOP" to "RUN", a slave diagnostic message is also generated to indicate the mode change to the DP master.

Structure of the DP Slave Diagnostic Information

The DP slave diagnostic information of the CP 242-8 is 8 bytes long and has the following structure:

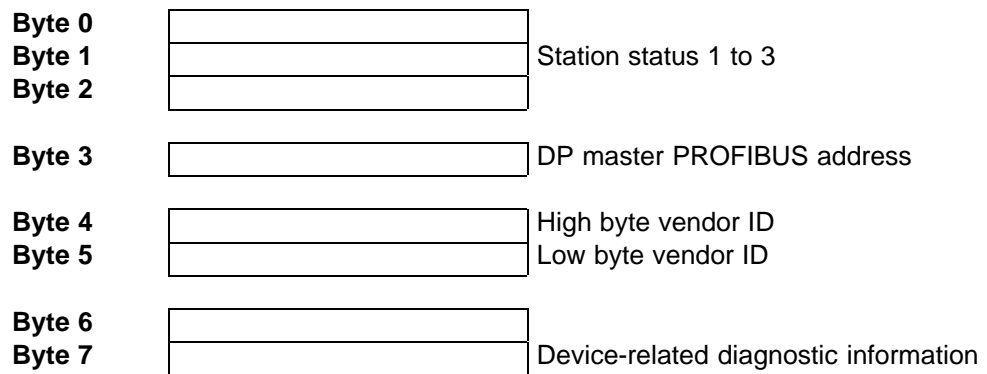

Access Mechanism

Read the manual of your DP master to find out the mechanisms you can use on the DP master to access diagnostic information.

The DP slave diagnostic information is explained below.

4.7.1 Station Status 1 to 3

Meaning

The station status provides an overview of the status of a DP slave.

The following applies to the individual error bits in the station status:

- 0: no error
- 1: error

Station Status 1

Byte	Bit	Value/meaning	Remedy
0	0	1: The CP 242-8 cannot be addressed by the DP master.	<ul style="list-style-type: none"> • Correct DP address set on the CP 242-8? • Bus connector connected? • RS 485 repeater set correctly? • External auxiliary voltage present on the CP 242-8?
	1	1: CP 242-8 not yet ready for data exchange.	Has the CP 242-8 already started up?
	2	1: Incorrect configuration data from the DP master. The required configuration is not supported by the CP 242-8.	Check the configuration.
	3	1: Device-related diagnostic information exists.	Evaluate the device-related diagnostic information (see Section 4.7)
	4	1: Function not supported, for example changing the DP address of the CP 242-8 by the DP master.	Check the configuration.
	5	1: The DP master cannot interpret the response of the CP 242-8.	Check the physical bus characteristics.
	6	1: The CP 242-8 detects an incorrect parameter assignment frame (e.g. incorrect length, incorrect ID number, incorrect parameters).	Check the configuration.
	7	1: The CP 242-8 was assigned parameters by a different DP master from the DP master that currently has access to the CP 242-8.	<p>This bit is always 1 if, for example, you are currently accessing the CP 242-8 with a PG or a different DP master.</p> <p>The DP address of the parameter assignment master is located in the diagnostic byte "master PROFIBUS address".</p>

Station Status 2

Bit	Value/meaning
0	1: The CP 242-8 needs to have parameters reassigned by the DP master.
1	1: A static diagnostic message exists.
2	1 : Bit always set to '1' on the CP 242-8.
3	1: The watchdog of the CP 242-8 is activated.
4	1: The CP 242-8 has received the "FREEZE" control command.
5	1: The CP 242-8 has received the "SYNC" control command.
6	0: Bit always set to '0'
7	1: The CP 242-8 is deactivated, in other words it is not taking part in the current processing.

Station Status 3

Value/meaning
Station status 3 is reserved and is irrelevant for diagnostics on the CP 242-8.

4.7.2 PROFIBUS Address of the DP Master and Vendor ID

Byte	Value	Value/meaning
3	xx H	PROFIBUS address of the DP master In slave diagnostics, byte 3 contains the hexadecimal address of the PROFIBUS master that assigned parameters to the CP 242-8.
4	80 H	Vendor ID of the CP 242-8
5	49H	In slave diagnostics, byte 4 and byte 5 also include the vendor ID of the CP 242-8.

4.7.3 Structure of the Device-Related Diagnostic Information

Byte	Value	Value/meaning
6	02H	Fixed value
7	Value in Bit 0: 0/1	0: PLC_RUN=1 → signals S7-200 CPU in RUN mode 1: PLC_RUN=0 → signals S7-200 CPU in STOP mode



Dealing with Problems / Error Displays

5

5.1	Replacing a Defective AS-i Slave / Automatic Address Programming	5-2
5.2	Error Displays of the CP 242-8 / Remediating Errors	5-3

5.1 Replacing a Defective AS-i Slave/Automatic Address Programming

Simple Replacement of AS-i Slaves

Using the automatic address programming function, you can replace failed AS-i slaves extremely simply.

Note

Remember that “automatic address programming” is only possible in the following situations:

- The CP 242-8 is in the protected mode.
- The AUTO_ADDR_ENABLE flag is set to 1.

and

- Only one AS-i slave has failed.
-

The sections below explain how to replace failed AS-i slaves using the automatic address programming function.

Detecting a Defective AS-i Slave

If the AUP LED is lit (only in the protected mode) this indicates the following:

- Exactly **one** slave has failed.
- Automatic address programming by the CP 242-8 is possible.

You can recognize the failed AS-i slave simply because the LED assigned to the slave flashes on the front panel. To do this, you must switch the CP 242-8 to the slave display (see Section 1.7.2)

To Replace the Defective Slave:

Replace the defective slave with an identical slave (same I/O configuration and ID code) with address zero (as shipped).

The CP 242-8 then programs this slave with the address of the original station that had failed.

The “AUP” display goes off. The CP 242-8 indicates the new slave in the LED display.

5.2 Error Indicators on the CP 242-8/ Dealing with Errors

The following table lists the possible causes of errors that can occur when operating the CP 242-8 and how to remedy the problem.

Table 5-1 Error Indicators on the CP 242-8/ Dealing with Errors

Error	Possible Cause	Remedy
BF LED lit (indicates an error on PROFIBUS)	Connection to the PROFIBUS DP master interrupted.	Check the attachment of the DP master and CP 242-8 to PROFIBUS.
	DP master in wrong mode.	Check/correct the mode on the DP master.
	Incorrect parameter assignment/configuration by the PROFIBUS DP master. The PROFIBUS address configured on the DP master does not match the address of the CP 242-8.	Check/correct the configuration of the DP master.
	External 24 V power supply not present.	Check external 24 V power supply.
DIA LED lit	The PLC_RUN bit is set to 0. (e.g. with "STOP" on the S7-200)	Switch the S7-200 to "RUN" and set PLC_RUN to 1 in the user program.
APF LED lit	The AS-i power supply unit is not connected or is defective.	Check the connection of the AS-i power supply unit and if necessary replace it.
	Power requirements of the AS-i slaves are too high. Result: Voltage on the AS-i cable too low.	Check the power requirements of the AS-i slaves. If necessary, supply the slaves with power externally.
	Short circuit on the AS-i cable.	Check the AS-i cable and the connected slaves.
SF lights up without pressing the SET button.	The CP 242-8 is defective. Internal EEPROM error.	Replace the CP 242-8.
SF is lit when the SET button is pressed.	A slave with address 0 exists when there is a change to the protected mode.	Remove the slave with address 0 from the AS-i cable.

Table 5-1 Error Indicators on the CP 242-8/ Dealing with Errors

Error	Possible Cause	Remedy
CER LED is permanently lit.	The CP 242-8 has not yet been configured.	Configure the CP 242-8 using the mode button on the front panel.
	A configured AS-i slave has failed (evaluate the slave display).	Replace the defective AS-i slave or configure the CP 242-8 again if the slave is not required.
	An unconfigured AS-i slave was connected to the AS-i cable.	Remove the AS-i slave or reconfigure the CP 242-8.
	An AS-i slave was connected whose configuration data (I/O configuration, ID code) do not match the values of the configured AS-i slave.	Check whether the wrong AS-i slave has been connected. If necessary, reconfigure the CP 242-8.
The CER display flickers, in other words a configured AS-i slave is lost sporadically.	Bad contact	Check the electrical connections of the AS-i slaves.
	Interference on the AS-i cable.	Check the correct grounding of the S7-200 and check the AS-i cable. Check that the shield of the AS-i power supply unit is connected correctly.
The CP 242-8 does not switch from the configuration mode to the protected mode.	The S7-200 CPU is in the "RUN" mode.	Switch the S7-200 CPU to "STOP". This sets the PLC_RUN bit to 0.
	The SET button was not pressed long enough.	Press the button for at least 0.5 seconds.
	A slave with address 0 is connected to the AS-i cable. The CP 242-8 cannot change to the protected mode as long as this slave exists.	Remove the slave with address 0.
The CP 242-8 does not switch from the protected mode to the configuration mode.	The S7-200 CPU is in the "RUN" mode.	Switch the S7-200 CPU to "STOP". This sets the PLC_RUN bit to '0'.
	Button not pressed long enough	Press the button for at least 0.5 seconds.

Table 5-1 Error Indicators on the CP 242-8/ Dealing with Errors

Error	Possible Cause	Remedy
After failure of an AS-i slave, the "AUP" display remains off.	The CP 242-8 is in the configuration mode.	"Automatic Programming" is not possible in the configuration mode. Program the address of the new AS-i slave with the addressing unit.
	More than one AS-i slave has failed.	Check the AS-i cable. If "APF" is displayed at the same time, check the power supply on the AS-i cable. If more than one AS-i slave is defective, program the address on the replaced AS-i slaves using the addressing unit.
	The CP 242-8 has detected non-configured AS-i slaves.	Remove the unconfigured AS-i slaves from the AS-i cable.
	The AUTO_ADDR_ENABLE flag is not set.	Set the bit with the appropriate commands or by pressing the SET button during AS-i Power Fail.
Automatic address programming is unsuccessful although the "AUP" display is lit.	The configuration data (I/O configuration, ID code) of the replaced AS-i slave do not match the values of the original AS-i slave.	Check whether the correct "replacement slave" was used. Compare the information from the manufacturer about configuration data. If you want to replace the original slave with a different type, assign the address with the addressing unit and reconfigure the CP 242-8 (for example by pressing the SET button).
	The replaced AS-i slave does not have the address "0".0	Set the address of the replaced AS-i slave with the addressing unit.
	The replaced AS-i slave is not correctly connected or is defective.	Check the connections of the AS-i slave and if necessary replace the AS-i slave.
The "CER" LED and the LEDs of active AS-i slaves flicker irregularly.	An extender is installed in the AS-Interface with "Line1" and "Line2" connections reversed.	Correct the connections on the extender.



AS-Interface Protocol Implementation Conformance Statement (PICS)



PICS for the CP 242-8

Table A-1

Vendor	SIEMENS AG
Product Name	CP 242-8 – AS-Interface Master / PROFIBUS DP Slave
Order Number	6GK7242-8DP00-0XA0
Version	1
Master Profile	M1
Date	31.12.1997

List of Master Functions Available

Table A-2

No.	Function or Call on the Host Interface (symbolic representation)	M1	Comment / Function implemented by / see Section
1	Image, Status = Read_IDI()	X	By access to the I/O data of the CP 242-8 module by the DP master.
2	Status = Write_ODI(Image)	X	By access to the I/O data of the CP 242-8 module by the DP master.
3	Status = Set_Permanent_Parameter(Addr, Param)	X	see Section 3.6.1
4	Param, Status = Get_Permanent_Parameter(Addr)	X	see Section 3.6.2
5	Status, GParam = Write_Parameter(Addr, Param)	X	see Section 3.6.3
6	Status, Param = Read_Parameter(Addr)	X	see Section 3.6.4
7	Status = Store_Actual_Parameters()	X	see Section 3.6.5
8	Status = Set_Permanent_Configuration(Addr, Config)	X	see Section 3.6.6
9	Status, Config = Get_Permanent_Configuration(Addr)	X	see Section 3.6.7

Table A-2 , (continued)

No.	Function or Call on the Host Interface (symbolic representation)	M1	Comment / Function implemented by / see Section
10	Status = Store_Actual_Configuration()	X	By pressing the SET button; or with the command Store_actual_configuration see Section 3.6.4
11	Status, Config = Read_Actual_Configuration(Addr)	X	see Section 3.6.9
12	Status = Set_LPS(List31)	X	see Section 3.6.10
13	Status, List31 = Get_LPS()	X	Read Lists and Flags / see Section 3.6.16
14	Status, List31 = Get_LAS()	X	Read Lists and Flags / see Section 3.6.16
15	Status, List32 = Get_LDS()	X	Read Lists and Flags / see Section 3.6.16
16.0	Status = Get_Flags()	X	Read Lists and Flags / see Section 3.6.16
16.1	Status, Flag = Get_Flag_Config_OK()	X	Read Lists and Flags / see Section 3.6.16
16.2	Status, Flag = Get_Flag_LDS.0()	X	Read Lists and Flags / see Section 3.6.16
16.3	Status, Flag = Get_Flag_Auto_Address_Assign()	X	Read Lists and Flags / see Section 3.6.16
16.4	Status, Flag = Get_Flag_Auto_Prog_Available()	X	Read Lists and Flags / see Section 3.6.16
16.5	Status, Flag = Get_Flag_Configuration_Active()	X	Read Lists and Flags / see Section 3.6.16
16.6	Status, Flag = Get_Flag_Normal_Operation_Active()	X	Read Lists and Flags / see Section 3.6.16
16.7	Status, Flag = Get_Flag_APF()	X	Read Lists and Flags / see Section 3.6.16
16.8	Status, Flag = Get_Flag_Offline_Ready()	X	Read Lists and Flags / see Section 3.6.16
17	Status = Set_Operation_Mode(Mode)	X	By pressing the SET button; or with the command Set_operation_mode see Section 3.6.10
18	Status = Set_Offline_Mode(Mode)	X	see Section 3.6.11
19	Status = Activate_Data_Exchange(Mode)	-	not implemented
20	Status = Change_Slave_Address(Addr1, Addr2)	X	see Section 3.6.14
21	Status = Set_Auto_Address_Enable	X	see Section 3.6.12
22	Status = Get_Auto_Address_Enable	X	Read Lists and Flags / see Section 3.6.16
23.1	Status, Resp = Cmd_Reset_ASI_Slave(Addr, RESET)	-	not implemented
23.2	Status, Resp = Cmd_Read_IO_Configuration(Addr, CONF)	X	see Section 3.6.24

Table A-2 , (continued)

No.	Function or Call on the Host Interface (symbolic representation)	M1	Comment / Function implemented by / see Section
23.3	Status, Resp = Cmd_Read_Identification_Code(Addr, IDCOD)	X	see Section 3.6.23
23.4	Status, Resp = Cmd_Read_Status(Addr, STAT)	X	see Section 3.6.15
23.5	Status, Resp = Cmd_Read_Reset_Status(Addr, STATRES)	X	see Section 3.6.22

Symbols in column 3 (M2)

Symbol	Meaning
X	Function exists
-	Function does not exist

How the AS-i cycle time depends on the number of connected slaves

The following table shows how the AS-i cycle time depends on the number of connected slaves.

Number of slaves	1	2	3	4	5	6	7	8
Cycle time in μs	307	459	609	762	914	1066	1218	1369

Number of slaves	9	10	11	12	13	14	15	16
Cycle time in μs	1521	1673	1825	1977	2129	2280	2432	2584

Number of slaves	17	18	19	20	21	22	23	24
Cycle time in μs	2736	2888	3041	3193	3345	3497	3649	3802

Number of slaves	25	26	27	28	29	30	31
Cycle time in μs	3954	4105	4258	4410	4562	4714	4866

The specified times apply assuming that no frames are repeated, there are no management calls and all slaves are synchronized.



Structure of the PROFIBUS DP Parameter Assignment and Configuration Frame

B

When You Require this Information

This section describes the structure of the parameter assignment and configuration frame for the CP 242-8 module. You require this information if you use configuration tools that cannot interpret the type or DDB file of the CP 242-8 module shipped on diskette with this manual.

Note

If you configure the CP 242-8 module using configuration tools such as STEP 7 or COM PROFIBUS, you do **not** require this information. The menus of these tools show you the options available for configuring/assigning parameters to the CP 242-8 module.

Configuration Frame

The configuration frame depends on the number of output bytes transferred to the CP 242-8 and the number of input bytes the DP master reads from the CP 242-8. The configuration frame also depends on whether or not byte-consistent or block-consistent transfer is required.

Number of output bytes DP Master	Number of input bytes on the DP master	Configuration frame block consistency (hexadecimal) Byte 0	Configuration frame byte consistency (hexadecimal) Byte 0
2	2	B1	31
4	4	B3	33
8	8	B7	37
16	16	BF	3F

Number of output bytes DP Master	Number of input bytes on the DP master	Configuration frame block consistency (hexadecimal)			Configuration frame byte consistency (hexadecimal)		
		Byte 0	Byte 1	Byte 2	Byte 0	Byte 1	Byte 2
32	32	C0	9F	9F	C0	1F	1F
64	64	C0	BF	BF	C0	3F	3F
4	16	C0	83	8F	C0	03	0F
8	32	C0	87	9F	C0	07	1F
16	64	C0	8F	BF	C0	0F	3F
16	4	C0	8F	83	C0	0F	03
32	8	C0	9F	87	C0	1F	07
64	16	C0	BF	8F	C0	3F	0F

Structure of the Parameter Assignment Frame

The parameter assignment frame of the CP 242-8 module is 8 bytes long. It consists of a 7-byte standard section complying with EN 50170 and an additional parameter byte for the CP 242-8

Standard Section

Byte 0		Station status, see /6/
Byte 1		Watchdog factor 1, see /6/
Byte 2		Watchdog factor 2, see /6/
Byte 3		T _{SDR} , see /6/
Byte 4	80H	Vendor ID, high byte, see /6/
Byte 5	49H	Vendor ID, low byte, see /6/
Byte 6		Group ID, see /6/

User-specific parameters

Byte 7	XXH ¹⁾
--------	-------------------

1) Range of values for byte 7: bit 0 =1: Start bit monitoring on; bit 1=1: Stop bit monitoring on; bit 2=0: Watchdog base =10 ms; bit 2 =1: Watchdog base = 1 ms;



References

/1/

AS-Interface Das Aktuator-Sensor-Interface für die Automation
Werner Kriesel, O.W. Madelung, Carl Hanser Verlag München Wien 1994

/2/

AS-Interface Complete Specification
can be ordered from the ASI Association e.V.

Address:

AS-International Association e.V.
Manager: Dr. Otto W. Madelung
Auf den Broich 4A
D - 51519 Odenthal
Germany

Tel.: +49 - 2174 - 40756

Fax.: +49 - 2174 - 41571

(The AS-i technology is promoted by the AS-Interface Association e. V.)

Internet address of the AS-International Association e.V.:

<http://www.as-interface.com>

/3/

SIMATIC NET Industrial Communications Networks

Catalog IK 10

The catalog can be ordered from your local SIEMENS branch office or distributor.

/4/

SIMATIC
S7-200 Programmable Controller, Hardware and Installation
Manual

/5/

SIMATIC
S7-200 Programmable Controller
System Manual
Siemens AG

/6/

Profibus & AS-Interface
Components on the Field Bus
Catalog ST PI

The catalog can be ordered from your local SIEMENS branch office or distributor.

/7/

SIMATIC NET
Industrial Communications Networks PROFIBUS Networks
Manual
Siemens AG

/8/

PROFIBUS standard EN 50170

/9/

SIMATIC
STEP 7-Micro/DOS
Manual
Siemens AG

Order numbers

The order numbers of the SIEMENS documentation listed above can be found in the catalogs "SIMATIC NET Industrial Communication, Catalog IK10" and "SIMATIC Programmable Controllers SIMATIC S7 / M7 / C7 – Components for Integrated Automation, Catalog ST70".

You can order these catalogs and obtain additional information from your local SIEMENS branch or distributor.



Notes on the CE Label

Product name:

CP 242-8 Order no.: 6GK7242-8DP00-0XA0

EU Directive EMC 89/336/EEC



The product listed above meets the requirements of the EU directive 89/336/EEC "Electromagnetic Compatibility".

The EU conformity certificates are available for the relevant authorities according to the EU directive and are kept at the following address:

Siemens Aktiengesellschaft
 Bereich Automatisierungstechnik
 Industrielle Kommunikation (A&D PT2)
 Postfach 4848
 D90327 Nuremberg
 Germany

Area of Application

The product meets the following requirements:

Area of application	Requirements	
	Noise emission	Noise immunity
Industrial	EN 50081-2 : 1993	EN 50082-2 : 1995

Installation instructions

The product meets the requirements providing you adhere to the instructions for installation and operation as described in the following documentation:

- This manual
- S7-200 Programmable Controller, Hardware and Installation /4/
- S7-200 Programmable Controller System Manual /5/

Information for Manufacturers of Machines

The product is not a machine in the sense of the EU directive on machines. There is therefore no conformity certificate for this product complying with the EU directive for machines 89/392/EEC.

If the product is integrated as part of a machine, it must be included in the conformity application of the manufacturer.

Glossary

AS-i

Actuator-sensor interface. A network system for the lowest field area of the automation range. It is suitable for networking sensors and actuators with control devices.

APF

AS-i Power Fail. Flag or LED display that indicates that the power supply on the AS-i cable is too low or has failed (for example failure of the AS-i power supply unit).

Bus parameter

Bus parameters control the way in which data is transmitted on the bus. Each → station on → PROFIBUS must use bus parameters that match the bus parameters of the other stations.

CLEAR mode

Mode of the DP master. Inputs are read cyclically, outputs remain set to 0.

CP

Communications processor: Module for communications tasks for installation in computers or programmable logic controllers.

Device database

Device database data (DDB) contain DP slave descriptions complying with EN 50170, Vol 2. The use of DDB makes it easier to configure the → DP master and → DP slaves.

Distributed peripheral I/Os (DP)

Input and output modules used in a distributed configuration by the CPU (central processing unit of the controller). The programmable logic controller and the distributed I/Os are connected via the → PROFIBUS bus system. For the programmable logic controllers, there is no difference between these I/Os and local process inputs or process outputs.

DP Master

Active station on → PROFIBUS that can send frames unsolicited when it is in possession of the token .

DP master system

A → DP master and all the → DP slaves with which this DP master exchanges data.

DP mode

In communication between the DP master and the DP slaves, a distinction is made between the following four modes:

- OFFLINE
- STOP
- CLEAR
- RUN

Each of these modes is characterized by defined actions between the DP master and DP slave.

DP slave

A → station with slave functions in → PROFIBUS DP.

Firmware; here the software that runs on the CP 242-8.

FREEZE mode

The FREEZE mode is a DP mode in which process data can be acquired from one, or several (group) or from all DP slaves at the same time. The point at which the data is acquired is indicated by the FREEZE command (this is a control frame for synchronization).

LAS

List of activated slaves.

LDS

List of detected slaves.

LPS

List of permanent slaves.

Maximum station delay

A → bus parameter for → PROFIBUS. The maximum station delay (max. TSDR) specifies the longest time required by one of the → stations in a → subnet between receiving the last bit of an unacknowledged → frame to sending the first bit of the next frame. A sender must wait until the max. TSDR has elapsed after sending an unacknowledged frame before it can send a further frame.

Minimum station delay

A → bus parameter for → PROFIBUS. The minimum station delay (min. TSDR) specifies the minimum time that the receiver of a → frame must wait before sending the confirmation or sending a further frame. The min. TSDR is based on the longest time required by a station in the sub system to receive a confirmation after sending the frame.

MPI

The multipoint interface (MPI) is the programming device interface of SIMATIC S7.

PROFIBUS

A field bus complying with EN 50170, Vol. 2. Previous name: SINEC L2.

PROFIBUS address

The PROFIBUS address is a unique identifier of a → station connected to → PROFIBUS. The PROFIBUS address is transferred in the → frame to address a station.

PROFIBUS DP

DP mode complying with EN 50170, Vol 2.

SIMATIC NET

Siemens SIMATIC Network and Communication. Product name for → networks and network components from Siemens (previously SINEC).

SIMATIC NET PROFIBUS

SIMATIC NET bus system for industrial application based on PROFIBUS. (previously SINEC L2).

SINEC

Previous product name for networks and network components from Siemens. New name: SIMATIC NET.

Special bit memory (SM)

Special bit memory provides status and control functions and is used to exchange information between the programmable controller and your program. Special bit memory can be used as bits, bytes, words and double words.

SYNC mode

The SYNC mode is a DP mode in which one, more than one (group) or all → DP slaves transfer data to their process outputs at the same time. The time at which the data is transferred is signaled by the SYNC command (a control frame for synchronization).

Target rotation time

A → bus parameter for → PROFIBUS. The token gives a → station on PROFIBUS the right to transmit frames. A station compares the token rotation time it has measured with the target rotation time. The difference between the two times decides whether only high or also low priority frames can be sent.

Token bus

Network access technique for bus access rights with more than one active station (used in PROFIBUS). The token is passed on from active station to active station. The following applies to each active station: The token passes through a complete rotation between a station sending and receiving the token.

UNFREEZE

Job for resetting the → FREEZE mode.

UNSYNC

Job for resetting the → SYNC mode.



Index

A

- Addressing
 - AS-i slaves, 3-3
 - example, 3-5
 - examples, 2-4
 - the CP 242-8 in the S7-200 CPU, 2-4
- Analog input and output words, access to, 2-17
- Analog input area, 2-18
- Analog module, 2-2, 2-14
- Analog output area, 2-20
- AS-Interface, cycle time, A-4
- AS-i. *See* AS-Interface
- AS-Interface
 - configuring with the SET button, 1-18
 - cycle time, 1-6
 - diagnostics on, 2-19
 - input data, 3-3
 - master, 1-4, 3-1
 - output data, 3-3
 - slave, replacing defective slaves, 5-2
 - vendor ID, 4-21
- Automatic address programming, 5-2

B

- Bank selection, 2-2
- Block consistency, 4-4
- Block consistent data transfer, 4-7
- Button
 - DISPLAY, 1-8, 1-11
 - SET, 1-8, 1-18
- Byte consistency, 4-4
- Byte consistent data transfer, 4-5

C

- CE label, D-1
- CLEAR, 4-16, 4-17

- Command interface, 3-9
 - change_slave_address, 3-31
 - command sequence, 3-10, 4-8
 - description of the AS-i commands, 3-13
 - functions, 3-9
 - read_actual_configuration, 3-26
 - set_operation_mode, 3-30
 - store_actual_configuration, 3-25
 - write_parameter, 3-20
- Command status, 3-17
- Commands, data for, 2-20
- Components of the product, 1-4
- Configuration frame, structure of, B-1
- Configuration mode, 1-14, 1-18
- Connection elements, 1-8, 1-9
- Contacts, 1-9
- Control byte, 2-13, 4-7
- Control elements, 1-8
- Convection, 1-7

D

- DDB file, 4-13
- Delta list, 2-19
- Diagnostics, structure of device-related, 4-21
- Digital module, 2-2, 2-7
- Display elements, 1-8
- DP data area, controlling access, 4-4
- DP interface, configuration by the DP master, 4-14
- DP master, 4-2
 - configuration of the CP 242-8, 4-13
- DP slave, 1-4
 - CP 242-8, 4-1
- DP slave diagnostics, 4-18
- DP status information, 4-11

E

Error displays, 5-1
Error register, 2-7, 2-14
 in the analog module, 2-16
 in the digital module, 2-9
ESD guidelines, 1-2
Expansion module, 2-2

F

FREEZE, 4-16, 4-17
Front panel, 1-8
Functional ground, 1-10

H

Handshake mechanism, 4-7

I

Identification register, 2-7, 2-14
 in the analog module, 2-15
 in the digital module, 2-8
Input data, 4-2
Input register, 2-7, 2-11
Installation, 1-7

L

LED, 1-11, 1-12
 row, 1-8

N

Noise immunity/grounding, 1-2

O

Output data, 4-2
Output register, 2-7, 2-13

P

Parameter assignment frame, structure of, B-1
Parameter assignment/configuration frame,
 4-13

PICS, A-1

Power supply, 1-5, 1-6, 1-9
 external, 1-10

Power supply unit, 1-2

Problems, 5-1

PROFIBUS address, 1-6, 4-21
 displaying, 1-16
 setting, 1-16

PROFIBUS DP, 4-1

 connection to, 1-10

 control commands, 4-16, 4-17

 master

 assignment of the output data, 3-4

 available master functions, A-1

 Slave, 1-4

Protected mode, 1-14, 1-18

S

Signaling diagnostic information, 3-7

Signaling errors, 3-7

Slave display, 1-14

 example of, 1-15

Standard operation, 3-2

Standard rail, 1-7

Station status, 4-19

Status byte, 2-11, 4-7

Status display, 1-12

STEP 7 Micro, 3-6

SYNC, 4-17

T

Technical specifications, 1-6

Transmission rate, PROFIBUS, 1-6, 4-16

Type file, 4-13

U

UNFREEZE, 4-17

UNSYNC, 4-17

User data, 3-6

 transferring, 4-2

User program, interface to, 2-1

V

Vendor ID, 4-21

To
Siemens AG
A&D PT2

D-76181 Karlsruhe

From:

Your name: -----
Your title: -----
Your company: -----
Street: -----
City, country: -----
Phone: -----

Please check any industry that applies to you:

- | | |
|--|---|
| <input type="checkbox"/> Automotive | <input type="checkbox"/> Pharmaceutical |
| <input type="checkbox"/> Chemical | <input type="checkbox"/> Plastic |
| <input type="checkbox"/> Electrical Machinery | <input type="checkbox"/> Pulp and Paper |
| <input type="checkbox"/> Food | <input type="checkbox"/> Textiles |
| <input type="checkbox"/> Instrument and Control | <input type="checkbox"/> Transportation |
| <input type="checkbox"/> Nonelectrical Machinery | <input type="checkbox"/> Other ----- |
| <input type="checkbox"/> Petrochemical | |



